

Service
Service
Service



Service Manual



TABLE OF CONTENTS

	Chapter
Location of PCB Boards	1-2
Versions Variation	1-2
Specifications	1-3
Measurement Setup	1-4
Service Aids	1-5
ESD & Safety Instruction	1-6
Lead-free soldering Information	1-7
Setting procedure & Repair Instructions.....	2
Disassembly Instructions & Service positions	3
Block & Wiring Diagram	4
VFD+Jack+VOL+Standby Board	5
MAIN Board.....	6
Power Board	7
AMP Board	8
Mechanical Exploded View & Part List.....	9
Revision List	10

© Copyright 2009 Philips Consumer Electronics B.V. Eindhoven, The Netherlands
All rights reserved. No part of this publication may be reproduced, stored in a retrieval system or transmitted, in any form or by any means, electronic, mechanical, photocopying, or otherwise without the prior permission of Philips.

Published by SL0912 Service Audio Printed in The Netherlands Subject to modification

GB 3141 785 33830

Version 1.0



PHILIPS

LOCATION OF PCB BOARDS

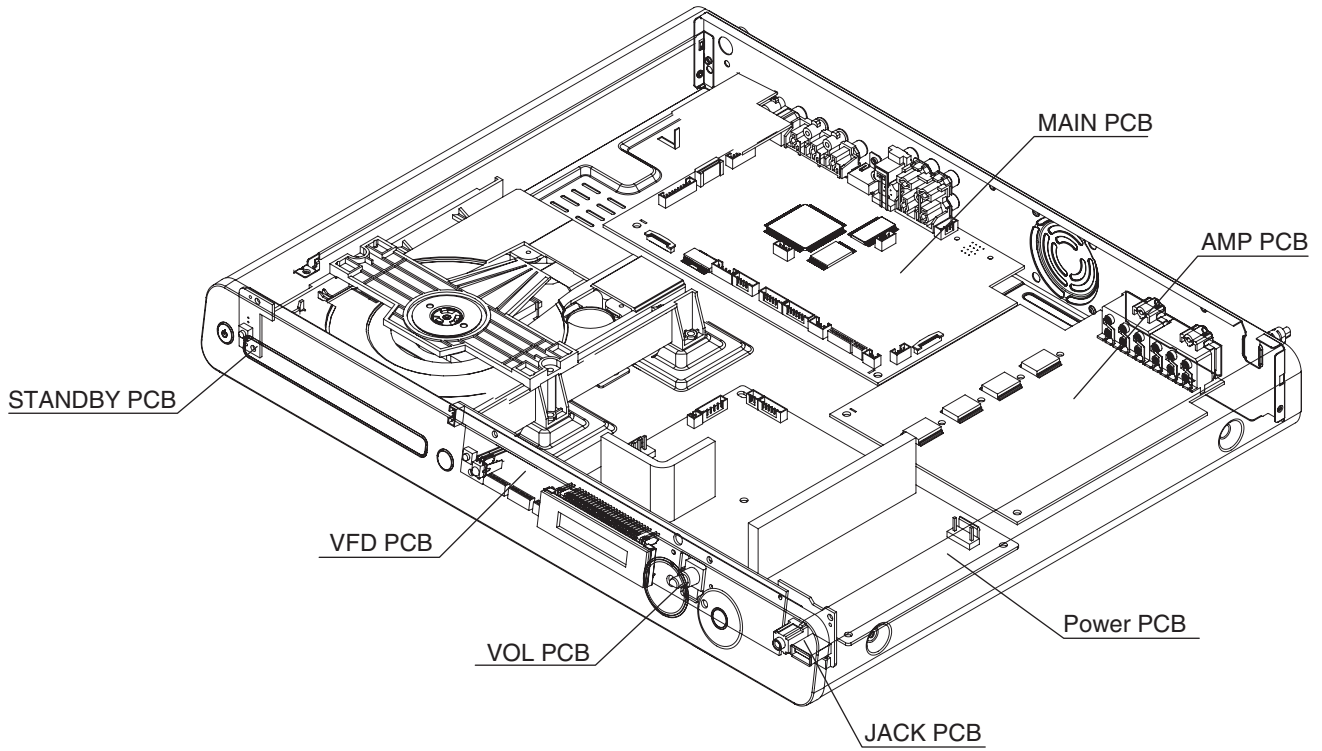

VERSION VARIATION:

Type/Versions	HTS3578
Features	/51
Output Power - 1200W	X
Voltage (220~240V)	X

SERVICE SCENARIO MATRIX:

Type/Versions	HTS3578
Board in used	/51
MAIN Board	C
Power Board	C
VFD+JACK+VOL+STANDBY Board	C
AMP Board	C

*C = Component Level Repair

SPECIFICATIONS

Playback media

DVD-Video, DVD+R/+RW, DVD-R/-RW, DVD+R DL, CD-R/CD-RW, Audio CD, Video CD/SVCD, Picture CD, MP3-CD, WMA-CD, DivX-CD, USB flash drive.

Amplifier

Total output power.....
 Home Theatre mode..... 1200 W RMS (2 X 260 + 4 X 170)
 Frequency response..... 40 Hz ~ 20 kHz
 Signal-to-noise ratio..... > 60 dB (A-weighted)
 Input sensitivity.....
 AUX1 400 mV
 AUX2 400 mV
 MP3 LINK 250 mV

Disc

Laser Type..... Semiconductor
 Disc diameter..... 12 cm / 8 cm
 Video decoding..... MPEG1/ MPEG2 / DivX / DivX Ultra
 Video DAC..... 12 bits, 108 MHz
 Signal system..... PAL / NTSC
 Video S/N 56 dB
 Audio DAC..... 24 bits / 96 kHz
 Frequency response.....
 4 Hz–20 kHz (44.1 kHz)
 4 Hz–22 kHz (48 kHz)
 4 Hz–44 kHz (96 kHz)
 PCM..... IEC 60958
 Dolby Digital IEC 60958, IEC 61937
 DTS IEC 60958, IEC 61937

Radio

Tuning range
 FM 87.5-108 MHz (50/100 kHz)
 26 dB quieting sensitivity FM 22 dBf
 IF rejection ratio..... FM 60 dB
 Signal-to-noise ratio..... FM 50 dB
 Harmonic distortion..... FM 3%
 Frequency response..... FM 180 Hz~ 10 kHz / ±6dB
 Stereo separation FM 26 dB (1 kHz)
 Stereo Threshold..... FM 29 dB

USB

Compatibility High Speed USB (2.0)
 Class support..... UMS (USB Mass Storage Class)
 File system FAT12, FAT16, FAT32

Main Unit

Power supply 220-240 V; ~50 Hz switchable
 Power consumption 200 W
 Standby power consumption < 1 W
 Dimensions (WxHxD) 435 x 57 x 365 (mm)
 Weight 3.63 kg

Speakers

System..... full range satellite
 Speaker impedance.....
 Front/Rear 4 Ohm
 Centre..... 3 Ohm
 Speaker drivers
 Centre..... 2 X 2.5" woofer + 1 X 2" tweeter
 Front/Rear 3" full range
 Frequency response..... 150 Hz ~ 20 kHz
 Dimensions (WxHxD)
 - Centre..... 440 x 105 x 75 (mm)
 - Front 262 x 1199 x 264 (mm)
 - Rear..... 262 x 1199 x 264 (mm)
 Weight
 - Centre..... 1.33 kg
 - Front..... 3.45 kg
 - Rear..... 3.38 kg

Subwoofer

Impedance..... 3 ohm
 Speaker drivers 203 mm (8") woofer
 Frequency response..... 40 Hz ~ 150 Hz
 Dimensions (WxHxD) 242 x 352 x 360 (mm)
 Weight 5.76 kg

Laser specification

Type..... Semiconductor laser GaAIAs (CD)
 Wave length..... 645–665 nm (DVD), 770–800 nm (CD)
 Output power..... 6 mW (DVD), 7 mW (VCD/CD)
 Beam divergence..... 60 degrees.

Specifications subject to change without prior notice.

MEASUREMENT SETUP

Tuner FM

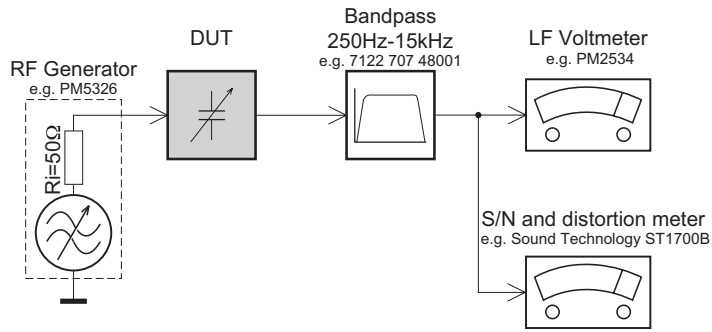

Use a bandpass filter to eliminate hum (50Hz, 100Hz) and disturbance from the pilotone (19kHz, 38kHz).

CD

Use Audio Signal Disc SBC429 4822 397 30184
(replaces test disc 3)

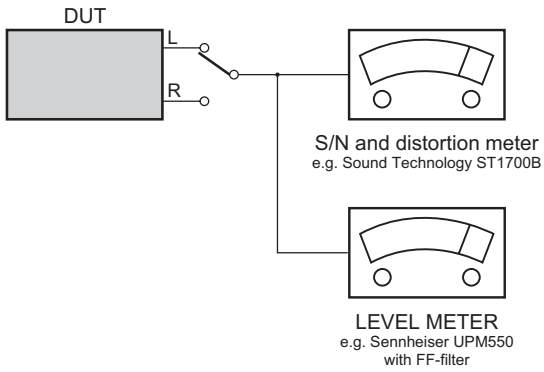

SERVICE AIDS

Service Tools:

Universal Torx driver holder	4822 395 91019
Torx bit T10 150mm	4822 395 50456
Torx driver set T6-T20	4822 395 50145
Torx driver T10 extended	4822 395 50423

Compact Disc:

SBC426/426A Test disc 5 + 5A	4822 397 30096
SBC442 Audio Burn-in test disc 1kHz	4822 397 30155
SBC429 Audio Signals disc	4822 397 30184
Dolby Pro-logic Test Disc	4822 395 10216

HANDLING CHIP COMPONENTS

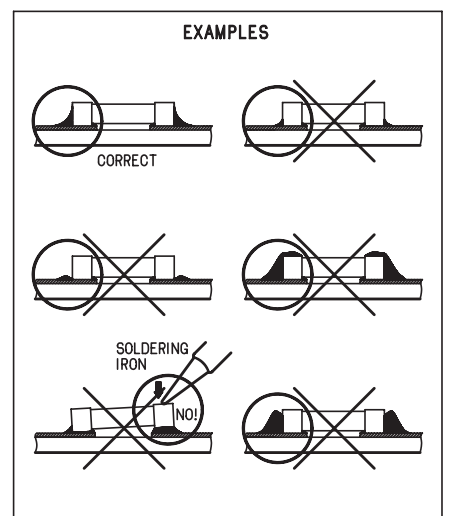
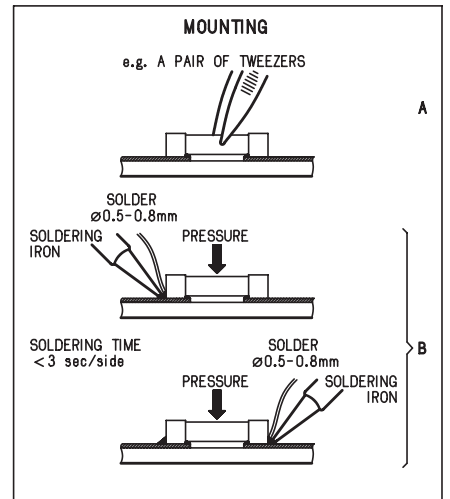
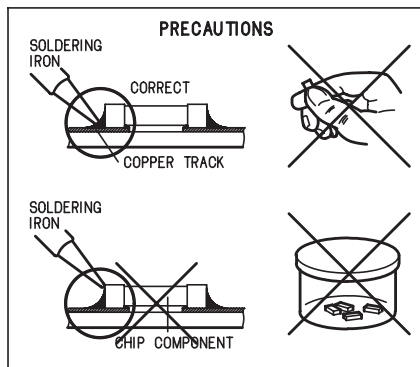
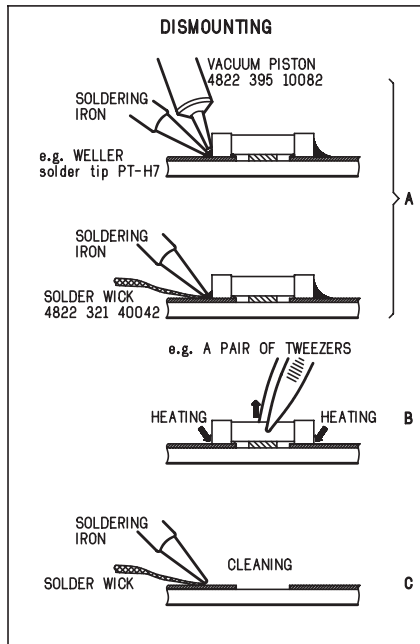
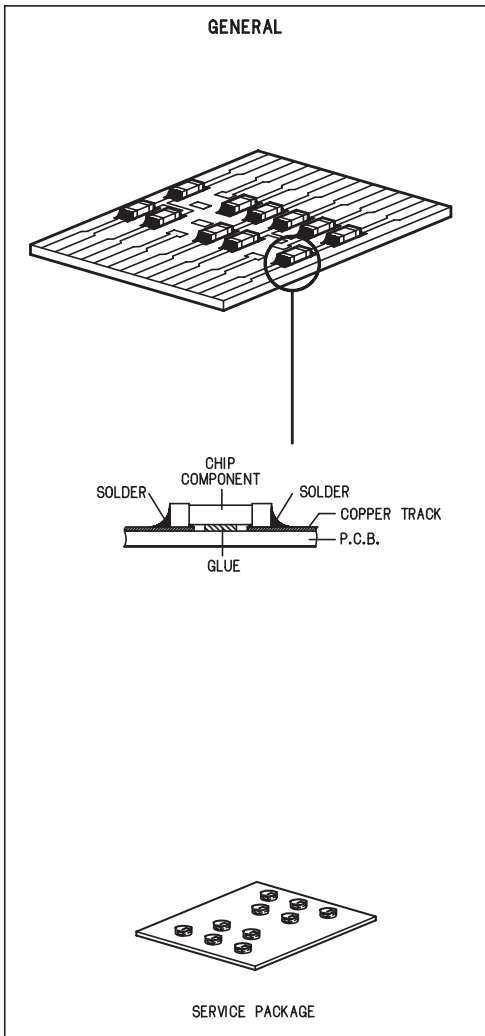

(GB) WARNING

All ICs and many other semi-conductors are susceptible to electrostatic discharges (ESD). Careless handling during repair can reduce life drastically.

When repairing, make sure that you are connected with the same potential as the mass of the set via a wrist wrap with resistance. Keep components and tools also at this potential.

(F) ATTENTION

Tous les IC et beaucoup d'autres semi-conducteurs sont sensibles aux décharges statiques (ESD).

Leur longévité pourrait être considérablement écourtée par le fait qu'aucune précaution n'est prise à leur manipulation.

Lors de réparations, s'assurer de bien être relié au même potentiel que la masse de l'appareil et enfiler le bracelet serti d'une résistance de sécurité.

Veiller à ce que les composants ainsi que les outils que l'on utilise soient également à ce potentiel.

(D) WARNUNG

Alle ICs und viele andere Halbleiter sind empfindlich gegenüber elektrostatischen Entladungen (ESD).

Unsorgfältige Behandlung im Reparaturfall kann die Lebensdauer drastisch reduzieren. Veranlassen Sie, dass Sie im Reparaturfall über ein Pulsarmband mit Widerstand verbunden sind mit dem gleichen Potential wie die Masse des Gerätes.

Bauteile und Hilfsmittel auch auf dieses gleiche Potential halten.

(NL) WAARSCHUWING

Alle IC's en vele andere halfgeleiders zijn gevoelig voor electrostatische ontladingen (ESD).

Onzorgvuldig behandelen tijdens reparatie kan de levensduur drastisch doen verminderen. Zorg ervoor dat u tijdens reparatie via een polsband met weerstand verbonden bent met hetzelfde potentiaal als de massa van het apparaat.

Houd componenten en hulpmiddelen ook op hetzelfde potentiaal.

(I) AVVERTIMENTO

Tutti IC e parecchi semi-conduttori sono sensibili alle scariche statiche (ESD).

La loro longevità potrebbe essere fortemente ridatta in caso di non osservazione della più grande cauzione alla loro manipolazione.

Durante le riparazioni occorre quindi essere collegato allo stesso potenziale che quello della massa dell'apparecchio tramite un braccialetto a resistenza.

Assicurarsi che i componenti e anche gli utensili con quali si lavora siano anche a questo potenziale.

(GB) ESD PROTECTION EQUIPMENT

Complete Kit ESD3 (small tablemat, wristband, connection box, estention cable and earth cable 4822 310 10671
Wristband tester 4822 344 13999

(GB)

Safety regulations require that the set be restored to its original condition and that parts which are identical with those specified, be used.

Safety components are marked by the symbol Δ .

(NL)

Veiligheidsbepalingen vereisen, dat het apparaat bij reparatie in zijn oorspronkelijke toestand wordt teruggebracht en dat onderdelen, identiek aan de gespecificeerde, worden toegepast.

De Veiligheidsonderdelen zijn aangeduid met het symbol Δ .

(F)

Les normes de sécurité exigent que l'appareil soit remis à l'état d'origine et que soient utilisés les pièces de rechange identiques à celles spécifiées.

Less composants de sécurité sont marqués Δ .

(D)

Bei jeder Reparatur sind die geltenden Sicherheitsvorschriften zu beachten. Der Originalzustand des Geräts darf nicht verändert werden; für Reparaturen sind Original-Ersatzteile zu verwenden.

Sicherheitsbauteile sind durch das Symbol Δ markiert.

(I)

Le norme di sicurezza esigono che l'apparecchio venga rimesso nelle condizioni originali e che siano utilizzati i pezzi di ricambio identici a quelli specificati.

Componenty di sicurezza sono marcati con Δ .

(GB)

After servicing and before returning set to customer perform a leakage current measurement test from all exposed metal parts to earth ground to assure no shock hazard exist, The leakage current must not exceed 0.5mA.

**(GB) Warning !**

Invisible laser radiation when open.
Avoid direct exposure to beam.

(S) Varning !

Osynlig laserstrålning när apparaten är öppnad och spärren är urkopplad. Betrakta ej strålen.

(SF) Varoitus !

Avatussa laitteessa ja suojalukituksen ohitettaessa olet alttiina näkymättömälle laserisäteilylle. Älä katso säteeseen!

(DK) Advarsel !

Usynlig laserstrålning ved åbning når sikkerhedsafbrydere er ude af funktion. Undgå udsættelse for stråling.

(F)

"Pour votre sécurité, ces documents doivent être utilisés par des spécialistes agréés, seuls habilités à réparer votre appareil en panne".

Pb(Lead) Free Solder

When soldering, be sure to use the pb free solder.

INDENTIFICATION:

Regardless of special logo (not always indicated)



one must treat all sets from **1 Jan 2005** onwards, according next rules:

Important note: In fact also products of year 2004 must be treated in this way as long as you avoid mixing solder-alloys (lead-free/ lead-free). So best to always use SAC305 and the higher temperatures belong to this.

Due to lead-free technology some rules have to be respected by the workshop during a repair:

- Use only lead-free solder alloy Philips SAC305 with order code 0622 149 00106. If lead-free solder-paste is required, please contact the manufacturer of your solder-equipment. In general use of solder-paste within workshops should be avoided because paste is not easy to store and to handle.
- Use only adequate solder tools applicable for lead-free solder alloy. The solder tool must be able
 - To reach at least a solder-temperature of 400°C,
 - To stabilize the adjusted temperature at the solder-tip
 - To exchange solder-tips for different applications.
- Adjust your solder tool so that a temperature around 360°C – 380°C is reached and stabilized at the solder joint. Heating-time of the solder-joint should not exceed ~ 4 sec. Avoid temperatures above 400°C otherwise wear-out of tips will rise drastically and flux-fluid will be destroyed. To avoid wear-out of tips switch off unused equipment, or reduce heat.
- Mix of lead-free solder alloy / parts with leaded solder alloy / parts is possible but PHILIPS recommends strongly to avoid mixed solder alloy types (leaded and lead-free).
If one cannot avoid or does not know whether product is lead-free, clean carefully the solder-joint from old solder alloy and re-solder with new solder alloy (SAC305).
- Use only original spare-parts listed in the Service-Manuals. Not listed standard-material (commodities) has to be purchased at external companies.
- Special information for BGA-ICs:
 - Always use the 12nc-recognizable soldering temperature profile of the specific BGA (for de-soldering always use the lead-free temperature profile, in case of doubt)
 - Lead free BGA-ICs will be delivered in so-called 'dry-packaging' (sealed pack including a silica gel pack) to protect the IC against moisture. After opening,

dependent of MSL-level seen on indicator-label in the bag, the BGA-IC possibly still has to be baked dry. (MSL=Moisture Sensitivity Level). This will be communicated via AYS-website.

Do not re-use BGAs at all.

- For sets produced before 1.1.2005 (except products of 2004), containing leaded solder-alloy and components, all needed spare-parts will be available till the end of the service-period. For repair of such sets nothing changes.
- On our website www.atyourservice.ce.Philips.com you find more information to:
 - BGA-de-/soldering (+ baking instructions)
 - Heating-profiles of BGAs and other ICs used in Philips-sets

You will find this and more technical information within the "magazine", chapter "workshop news".

For additional questions please contact your local repair-helpdesk.

System , Region Code , etc. Setting Prochure

1)System Reset

- Press "SETUP" button on R/C,TV will show setup menu.
- Select the menu using the ▼ and ► on R/C.
- Go preference page to do system reset.

2)Region Code Change

- In open mode, press "9" "9" "9" on R/C,then input desired number to change region code :

- | | |
|---|-----------------------|
| 1 | USA |
| 2 | EU |
| 3 | AP |
| 4 | Australia ,NZ , Latam |
| 5 | Russia , INDIA |
| 6 | CHINA |

3)Version Control Change

- In open mode, press "1" "5" "9" on R/C.
- Press "ok" button to confirm.
- TV will show message as below:

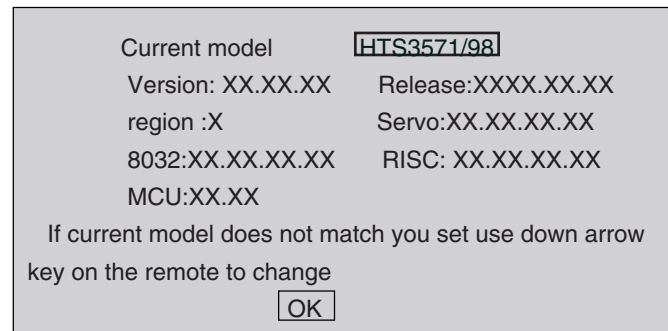

4)Password Change

- Press "SETUP" button on R/C,TV will show setup menu.
- Select the menu using the ▼ and ► on R/C.
- Go preference page select "password" to change.
 * 000000 is default password supplied.

5)Check on the Software Version

- Open the CD Door.
- Press "INFO" button on R/C.
- TV will show the version on screen.

6)Trade model

- Press "Open/Close " button on R/C.
- Press "2" "5" "9" on R/C,VFD will display "TRA ON " or "TRA OFF".

8) Produce to Change Tuner Grid

- (only applicable for certain regions)
 In some countries, the frequency step between adjacent channels in the FM band is 50kHz (100kHz in some areas).
- Press "source" to select "FM".

- In "FM" playback mode, press & hold "play/pause" button until Grid 9" or "Grid 10" appears.
 Note: repeating the same action will toggle back to it previous tuning grid setting.
 * "Grid 10" is default for/98 version.

7) Upgrading new software

- Copy "software files" into a CD-R.
- Open the CD Door,then insert the CD-R program disc.
- Close the CD Door.
- VFD will show:
 "Loading"
 "Erase" -- erase the flash memory
 "Writing" about 1 minute
 "done "

* the system will switch off and on again automatically.

- OSD will show:

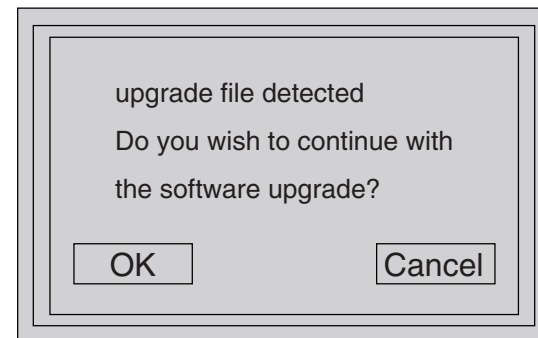

- Select "OK", OSD will show:

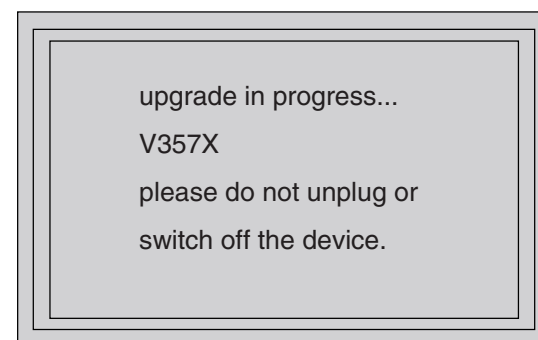

CAUTION!

This information is confidential and may not be distributed.Only a qualified service person should reprogram the Region Code.

System , Region Code , etc. Setting Prochure

1)System Reset

- Press "SETUP" button on R/C,TV will show setup menu.
- Select the menu using the ▼ and ► on R/C.
- Go preference page to do system reset.

2)Region Code Change

- In open mode, press "9" "9" "9" on R/C,then input desired number to change region code :

1	USA
2	EU
3	AP
4	Australia ,NZ , Latam
5	Russia , INDIA
6	CHINA

3)Version Control Change

- In open mode, press "1" "5" "9" on R/C.
- Press "ok" button to confirm.
- TV will show message as below:

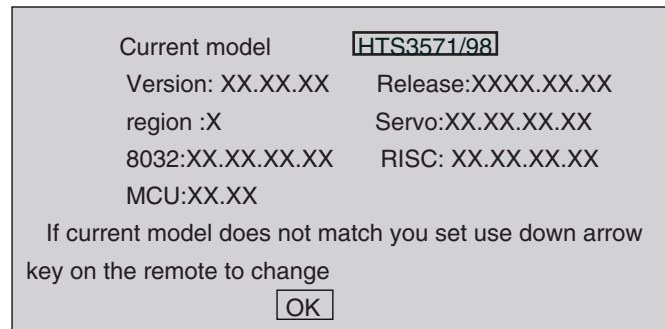

4)Password Change

- Press "SETUP" button on R/C,TV will show setup menu.
 - Select the menu using the ▼ and ► on R/C.
 - Go preference page select "password" to change.
- * 000000 is default password supplied.

5)Check on the Software Version

- Open the CD Door.
- Press "INFO" button on R/C.
- TV will show the version on screen.

6)Trade model

- Press "Open/Close " button on R/C.
- Press "2" "5" "9" on R/C,VFD will display "TRA ON " or "TRA OFF".

8) Produce to Change Tuner Grid

(only applicable for certain regions)

In some countries, the frequency step between adjacent channels in the FM band is 50kHz (100kHz in some areas).

- Press "source" to select "FM".

- In "FM" playback mode, press & hold "play/pause" button until Grid 9" or "Grid 10" appears.

Note: repeating the same action will toggle back to it previous tuning grid setting.

* "Grid 10" is default for/98 version.

7) Upgrading new software

- Copy "software files" into a CD-R.
- Open the CD Door,then insert the CD-R program disc.
- Close the CD Door.
- VFD will show:

"Loading"
 "Erase" -- erase the flash memory
 "Writing" about 1 minute
 "done "

* the system will switch off and on again automatically.

- OSD will show:

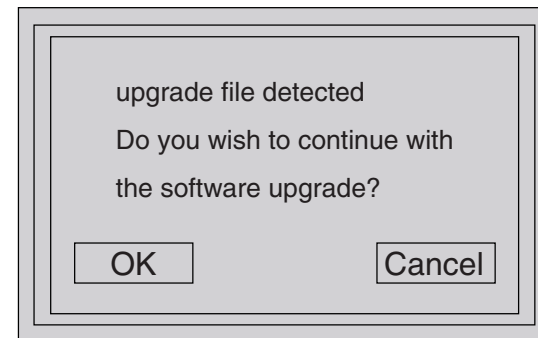

- Select "OK", OSD will show:

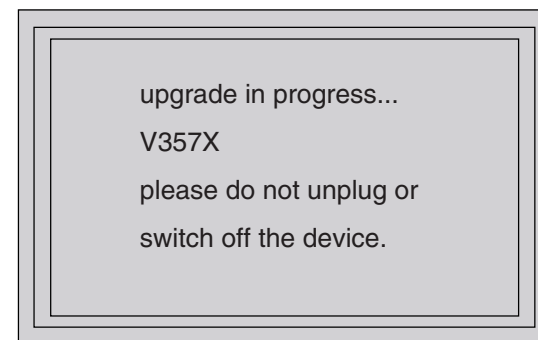

CAUTION!

This information is confidential and may not be distributed.Only a qualified service person should reprogram the Region Code.

MAIN UNIT REPAIR CHART 1/3

- A**
 All Function
 No Working
- B**
 Power Supply
 No Working
- C**
 All Function
 No Sound
- D**
 KARAOKE input
 No Sound
- E**
 Audio line IN
 No Output
- G**
 DVD Audio
 No Sound
- H**
 MP3 In
 No Sound
- I**
 COAXIAL In
 No Sound
- L**
 Tuner No Sound
- M**
 No Optical Input
- O**
 HDMI No Output
- P**
 No CVBS Output
- Q**
 No Y Pr Pb output

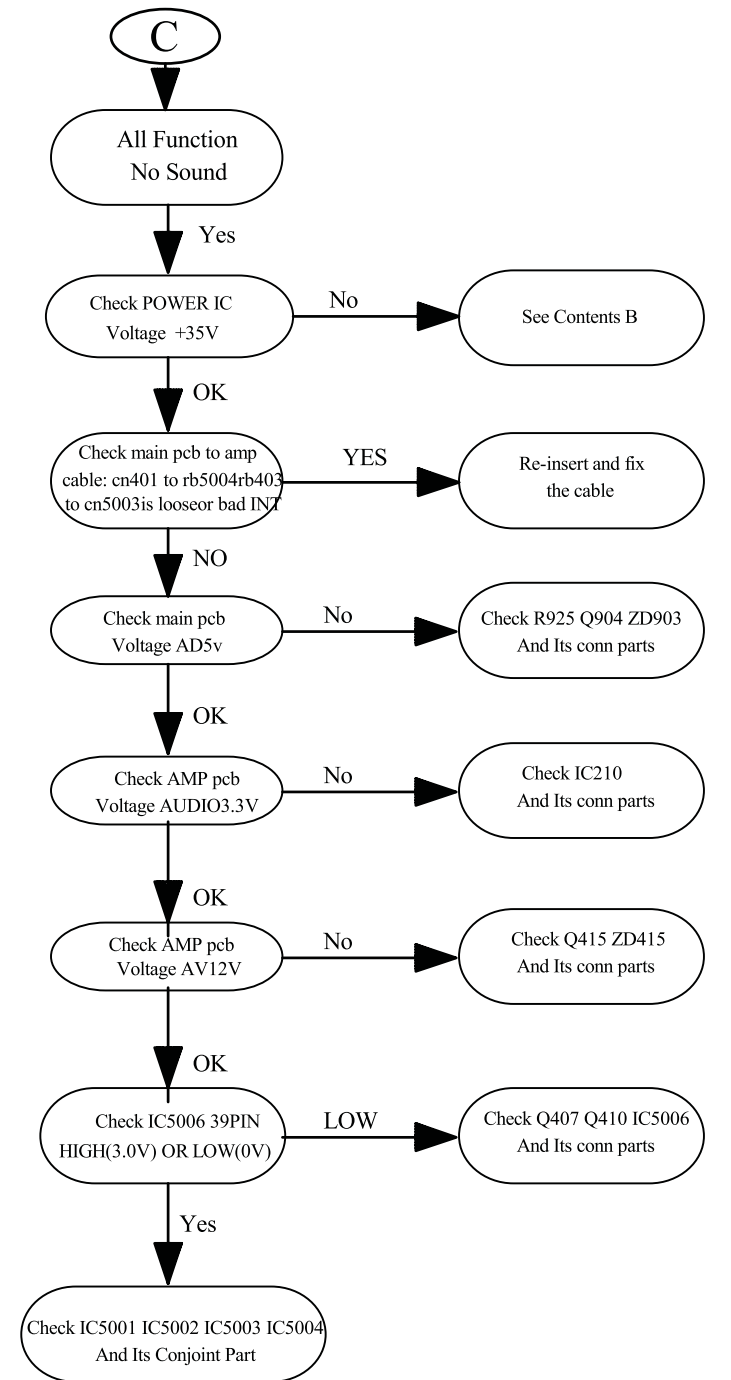
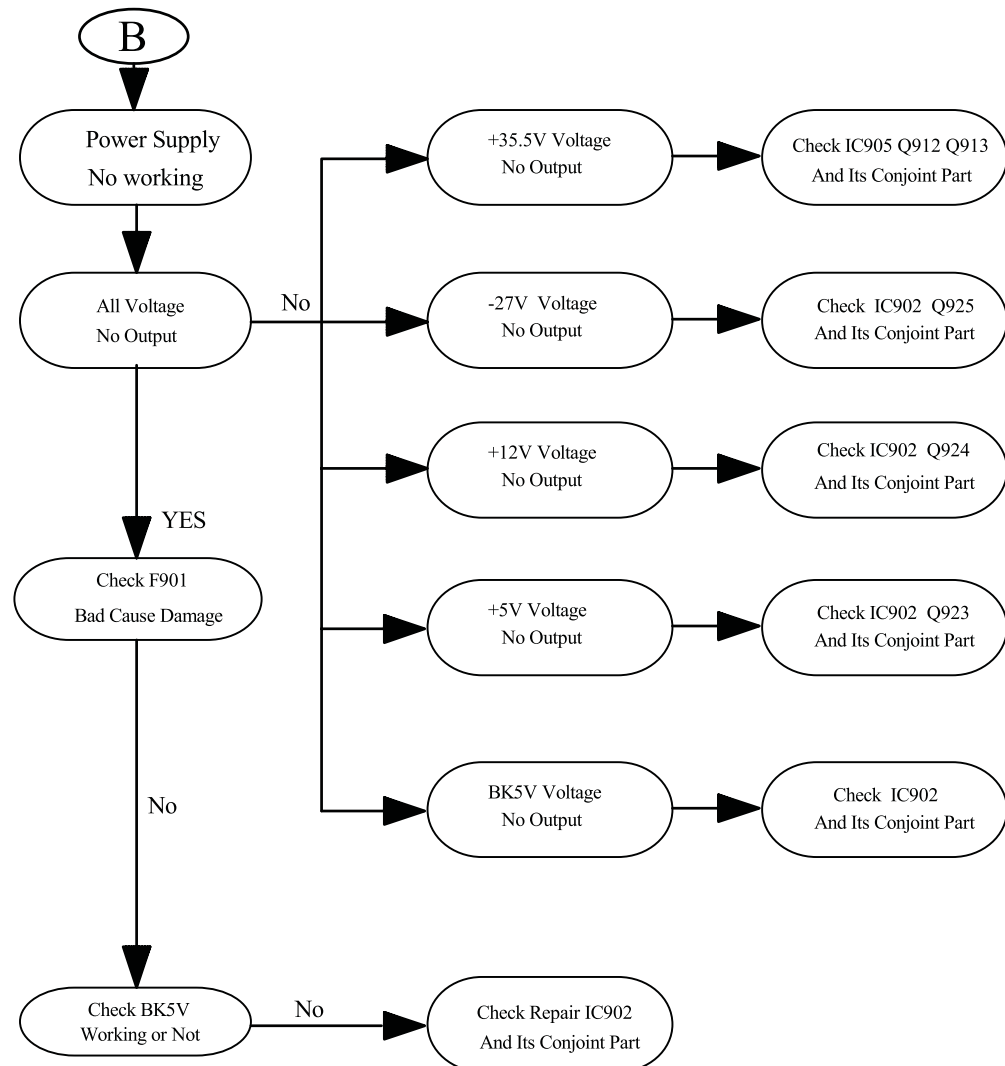
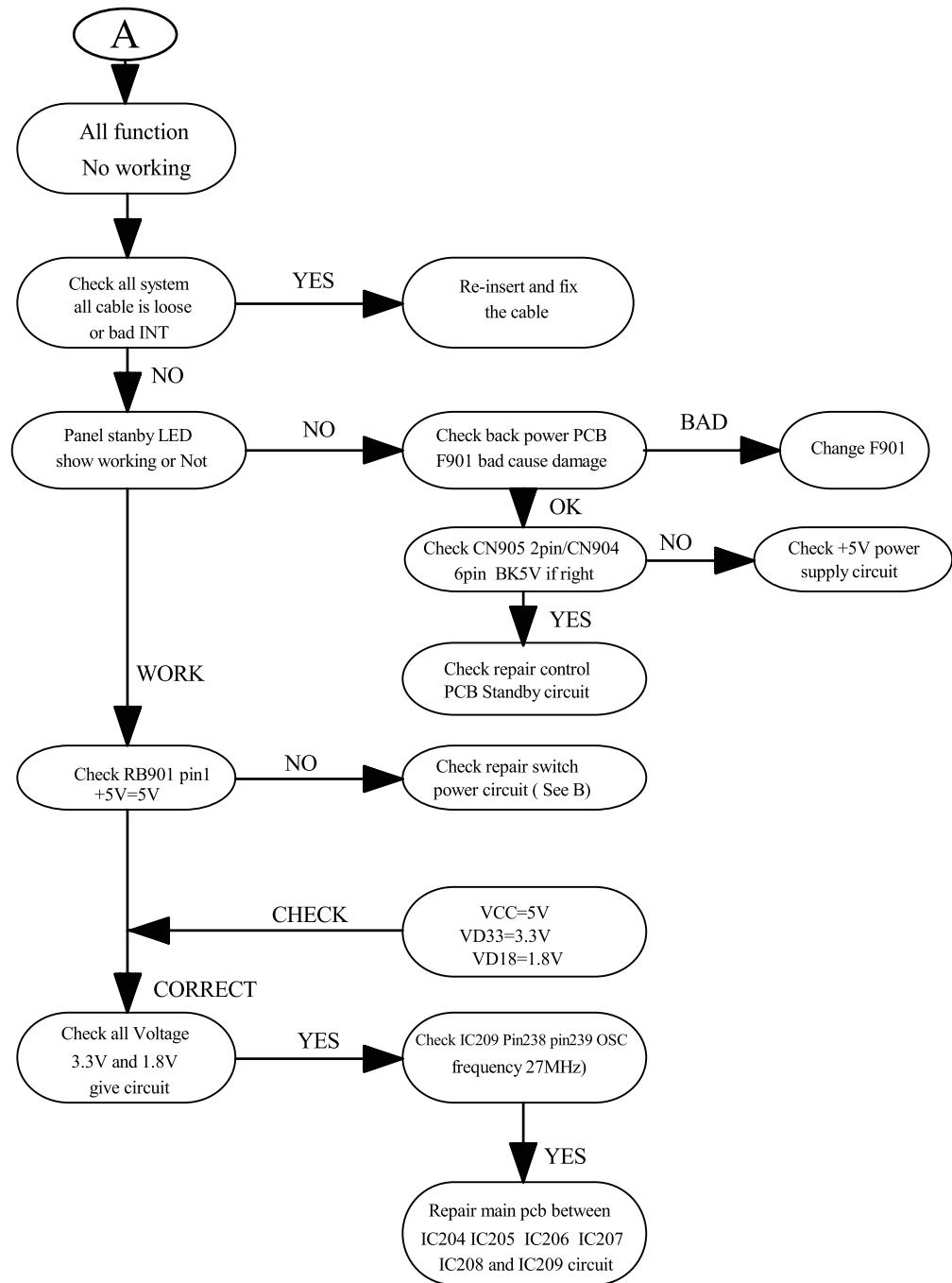

MAIN UNIT REPAIR CHART 2/3

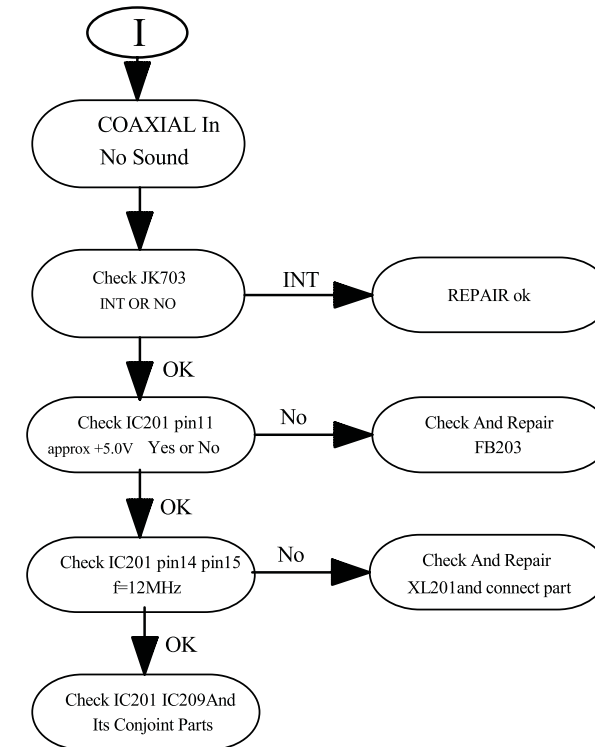
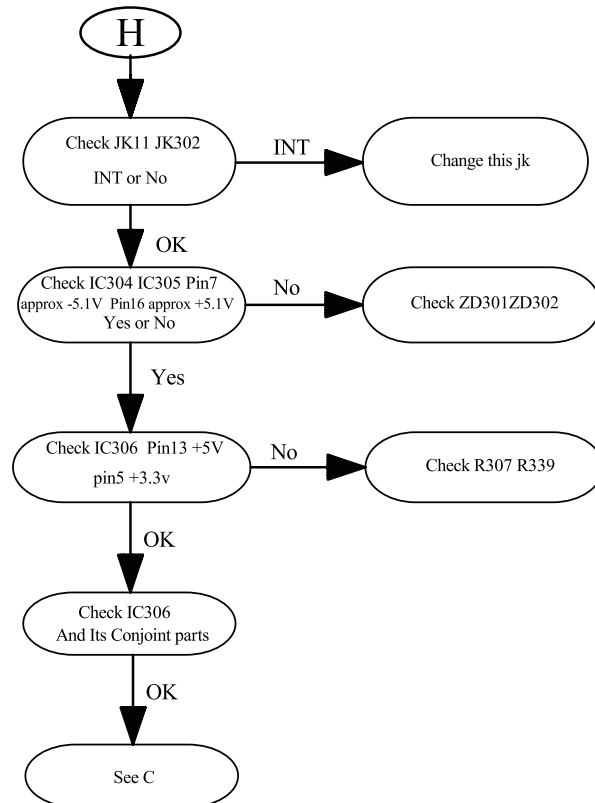
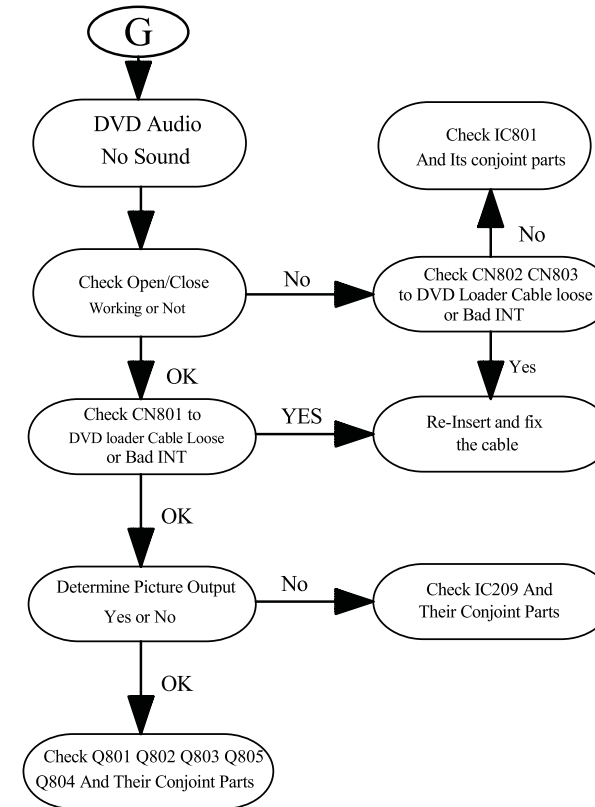
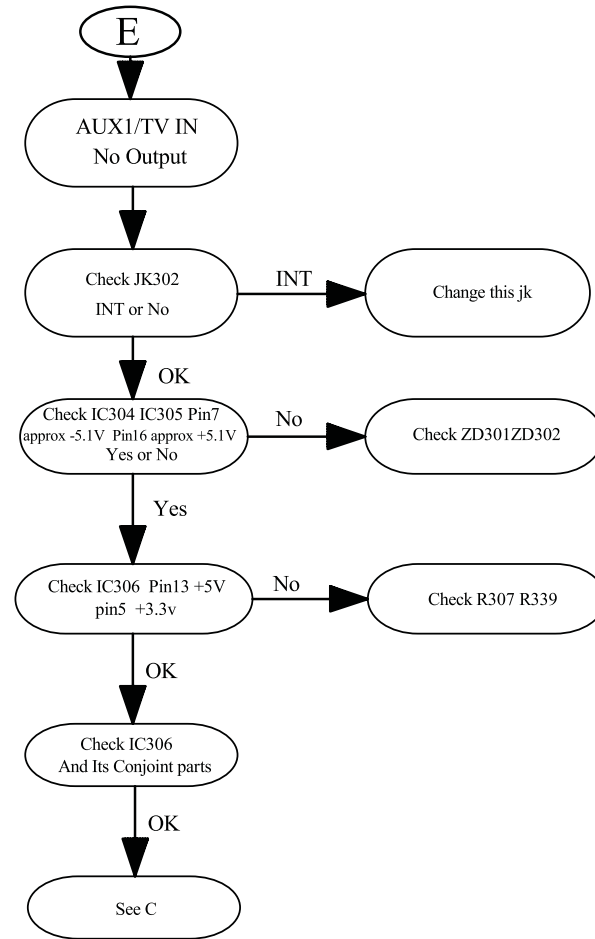
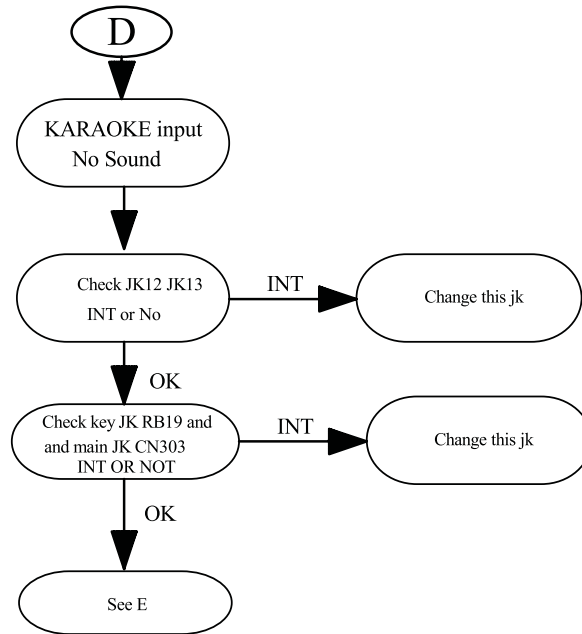

MAIN UNIT REPAIR CHART 3/3

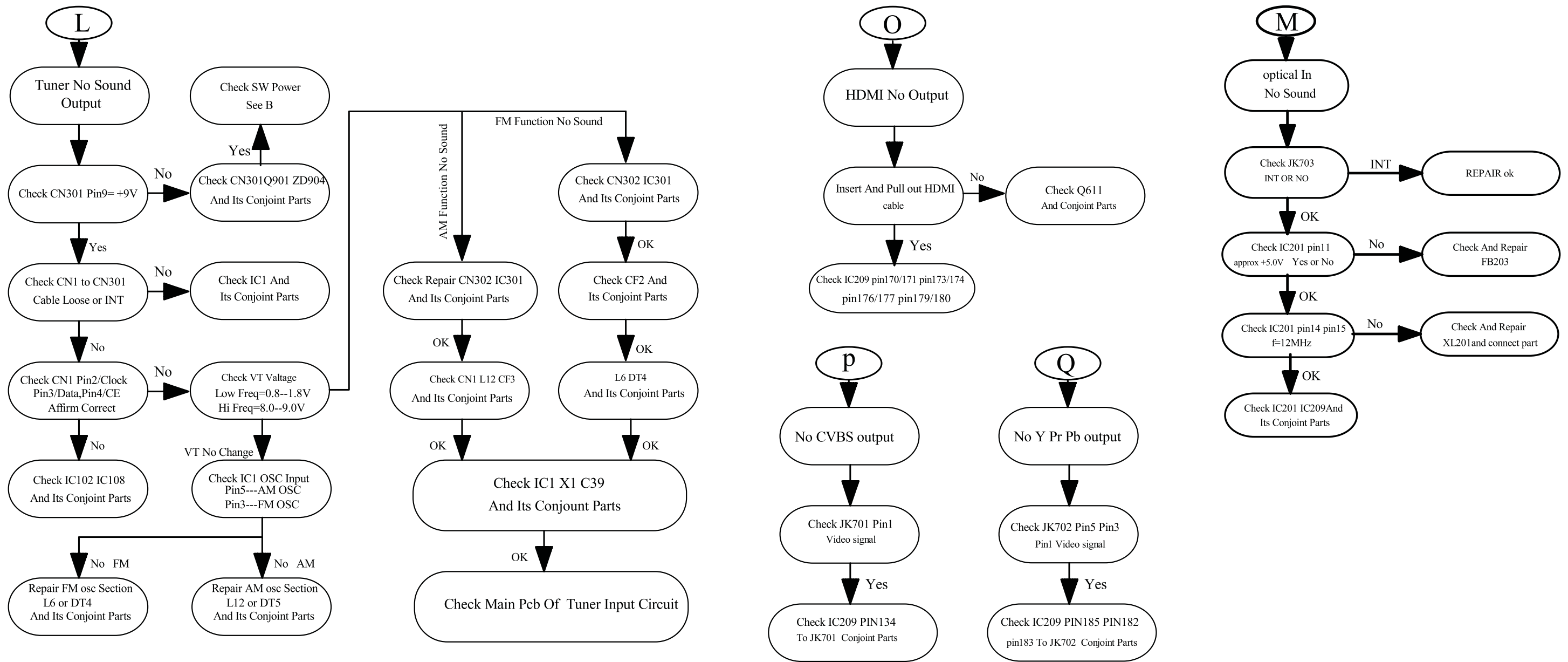

DISASSEMBLY INSTRUCTIONS

Dismantling of the Front Panel Assemble

- 1) Open the DVD Tray by using the Open/Close Button while the Set is ON and disconnect the mains supply after removing the Tray Cover.
Note: If this is not possible, the DVD Tray has to be open manually.
Take a mini screw driver about 2mm diameter and make a marking 24mm from the tip as shown in figure 2 . Place the set on its side, insert the mini screw driver till the marking and slide it towards the left as shown in figure 1 until the Tray moves out of the Front Panel.
- 2) Return the set to its upright position and remove the Tray Cover as shown in Figure 3 and close the tray manually by pushing it back in.

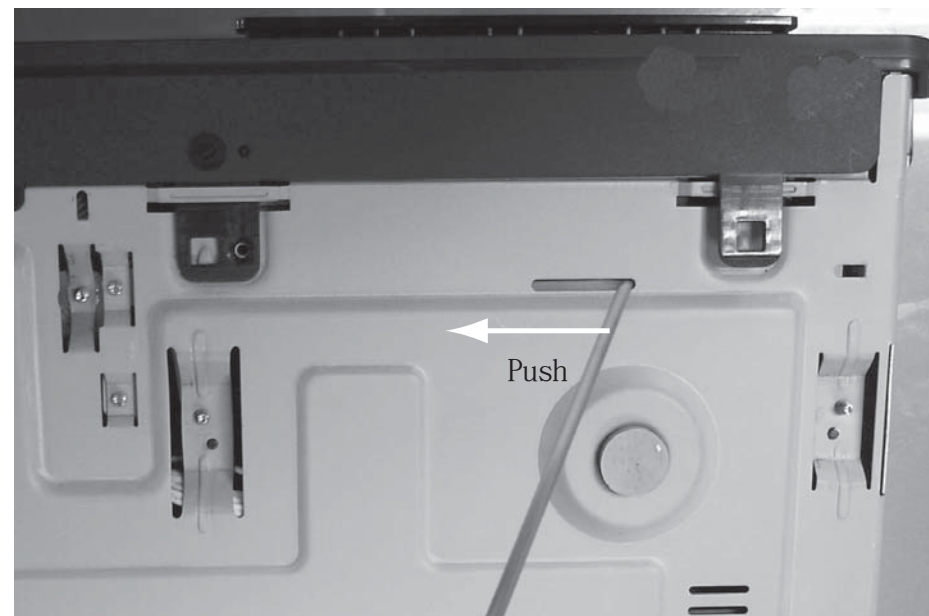

Figure 1

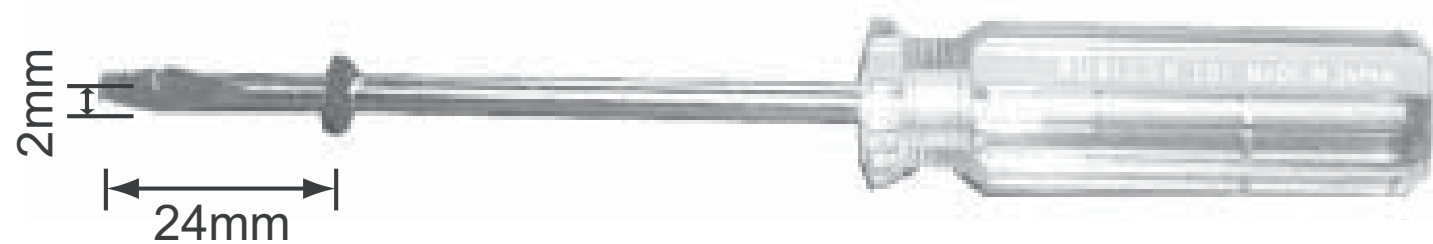

Figure 2

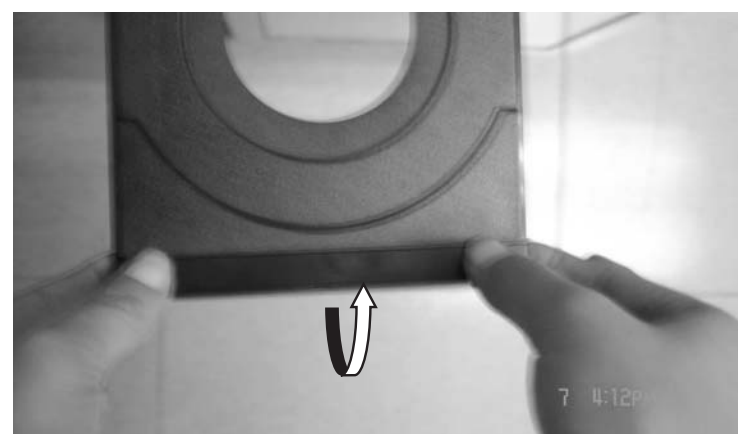

Figure 3

- 3) Loosen 7 screws and remove the Top Cover by lifting the rear portion upwards before sliding it out towards the rear.
 - 1 screw "A" each on the left & right side as shown in figure 4.
 - 5 screws "B" at the back panel as shown in figure 5.
- 4) Loosen 5 screws "C" at the front panel bracket as shown in figure 6, and loosen 1 screw "D" at the front panel bottom as shown in figure 7 to remove front panel.

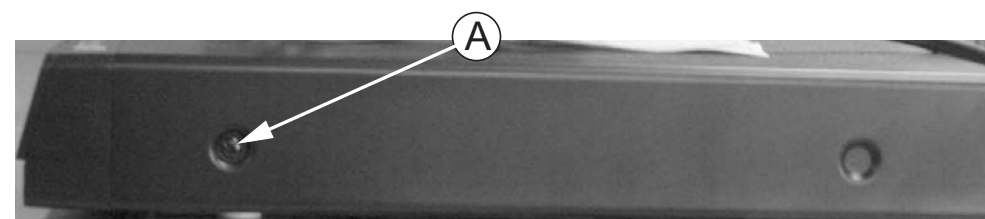

Figure 4

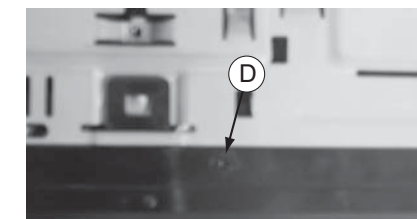

Figure 7

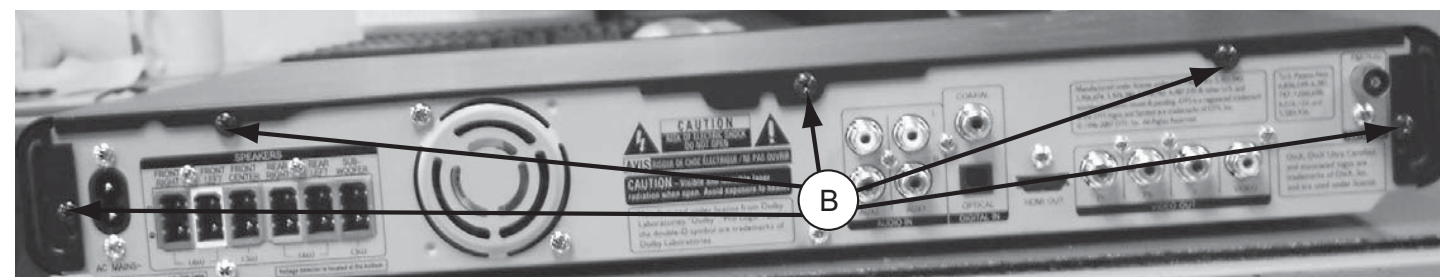

Figure 5

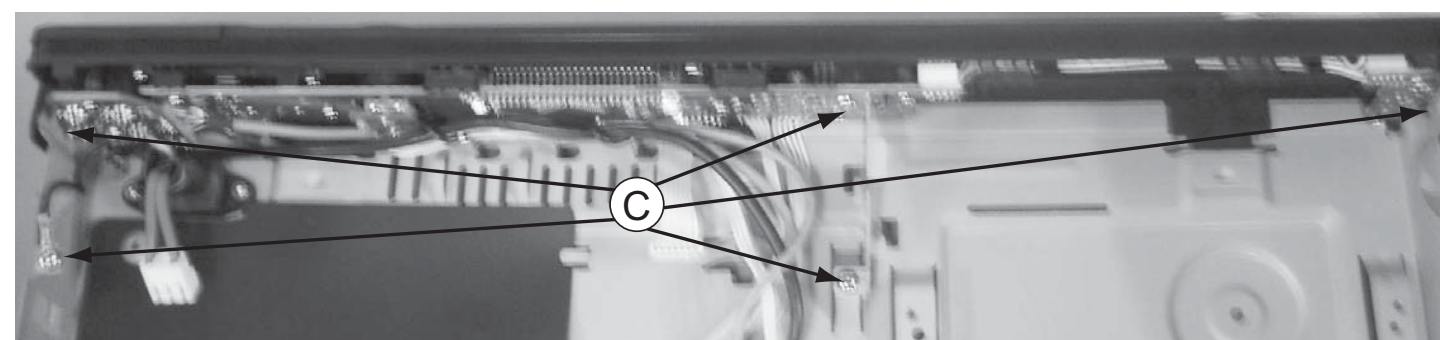

Figure 6

Dismantling of the DVD Module

- 1) Loosen 4 screws "E" at the DVD Module as shown in figure 8.

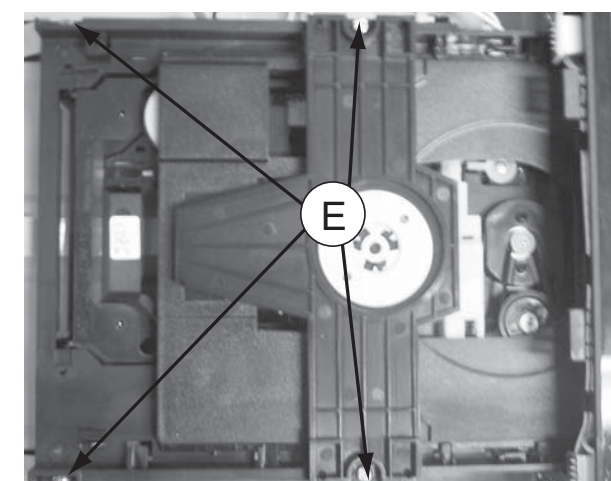

Figure 8

Dismantling of the VFD+JACK+VOL+STANDBY Board

- 1) Loosen 10 screws "F" on the top of VFD+JACK+VOL+STANDBY Board as shown in figure 9.

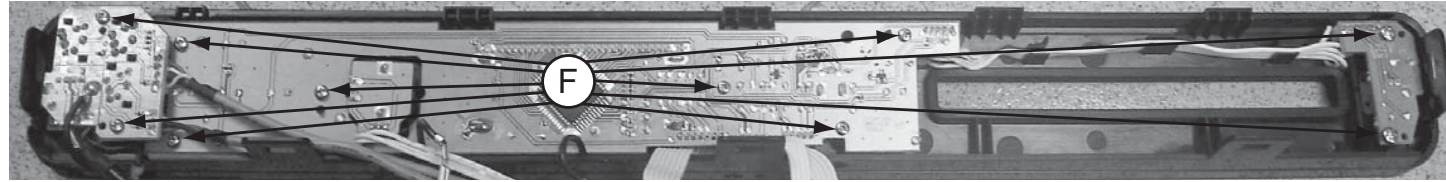

Figure 9

Dismantling of the Main Board

- 1) Loosen 2 screws "G" on the top of Main Board as shown in figure 10.
- 2) Loosen 6 screws "H" at the back panel as shown in figure 11.

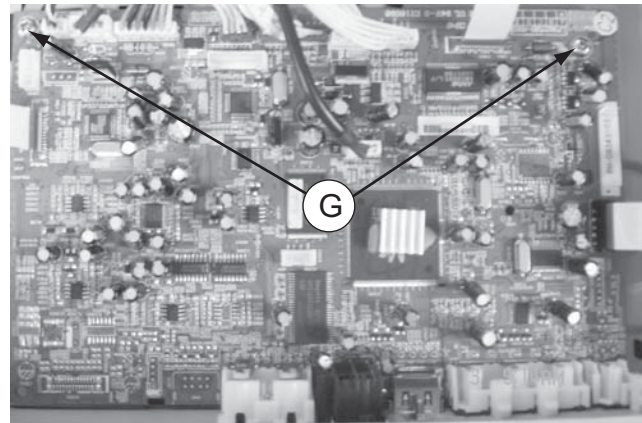

Figure 10



Figure 11

Dismantling of the Power Board

- 1) Loosen 5 screws "I" on the top of Power Board as shown in figure 12.

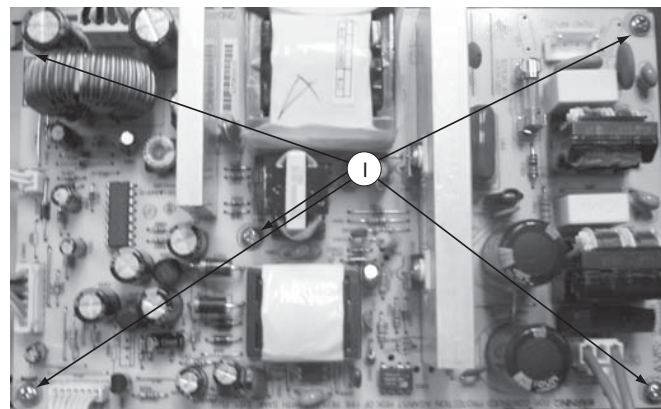

Figure 12

Dismantling of the AMP Board

- 1) Loosen 2 screws "J" on the top of AMP Board as shown in figure 13.
- 2) Loosen 2 screws "K" at the back panel as shown in figure 14.

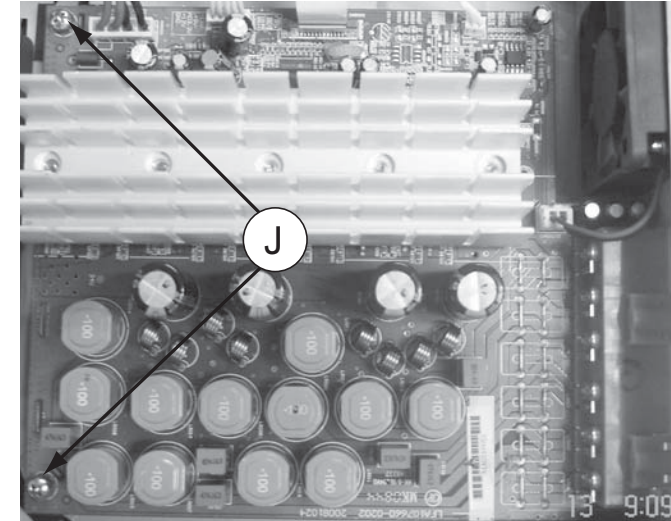

Figure 13

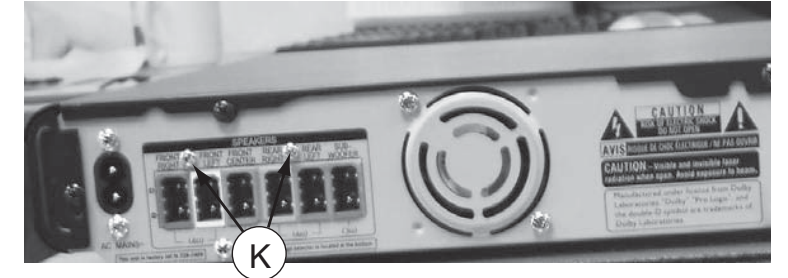
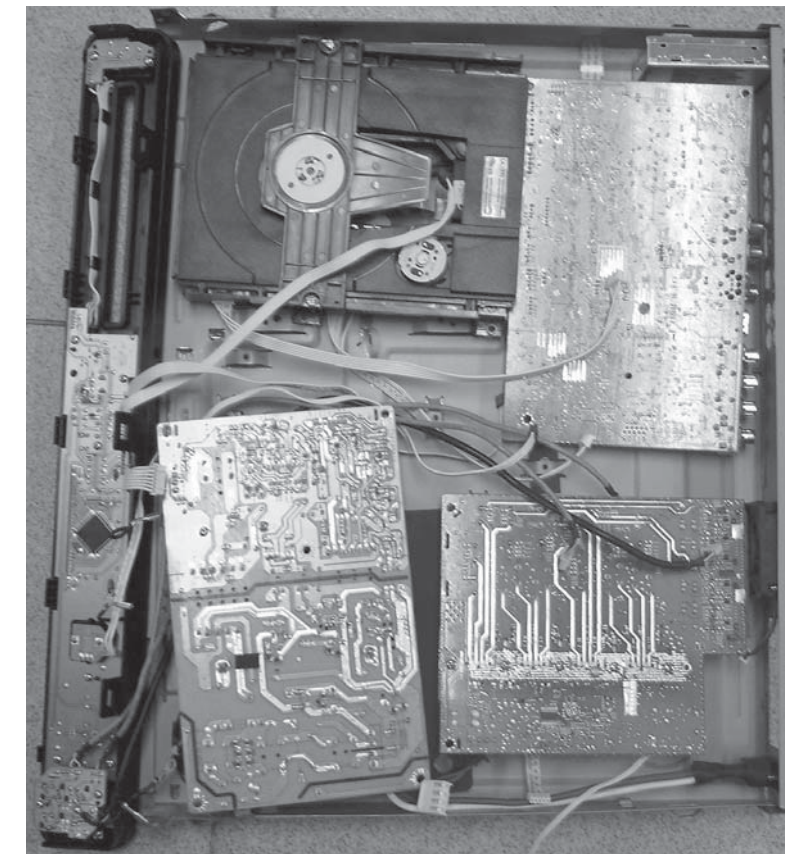

Figure 14

SERVICE POSITIONS

Service position A



Note: In some service positions the components or copper patterns of one board may risk touching its neighbouring pc boards or metallic parts. To prevent such short-circuit use a piece of hard paper or other insulating material between them.

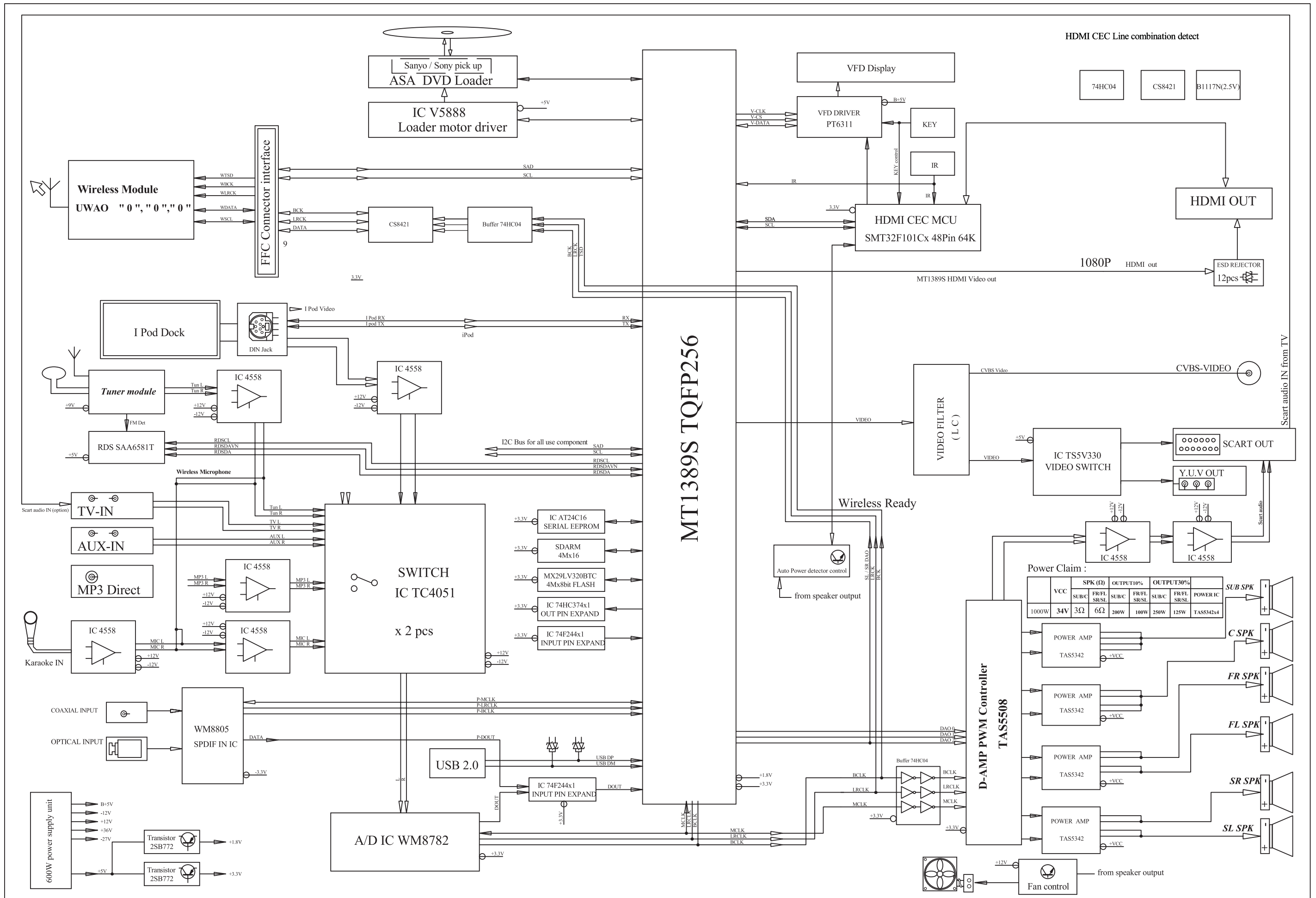

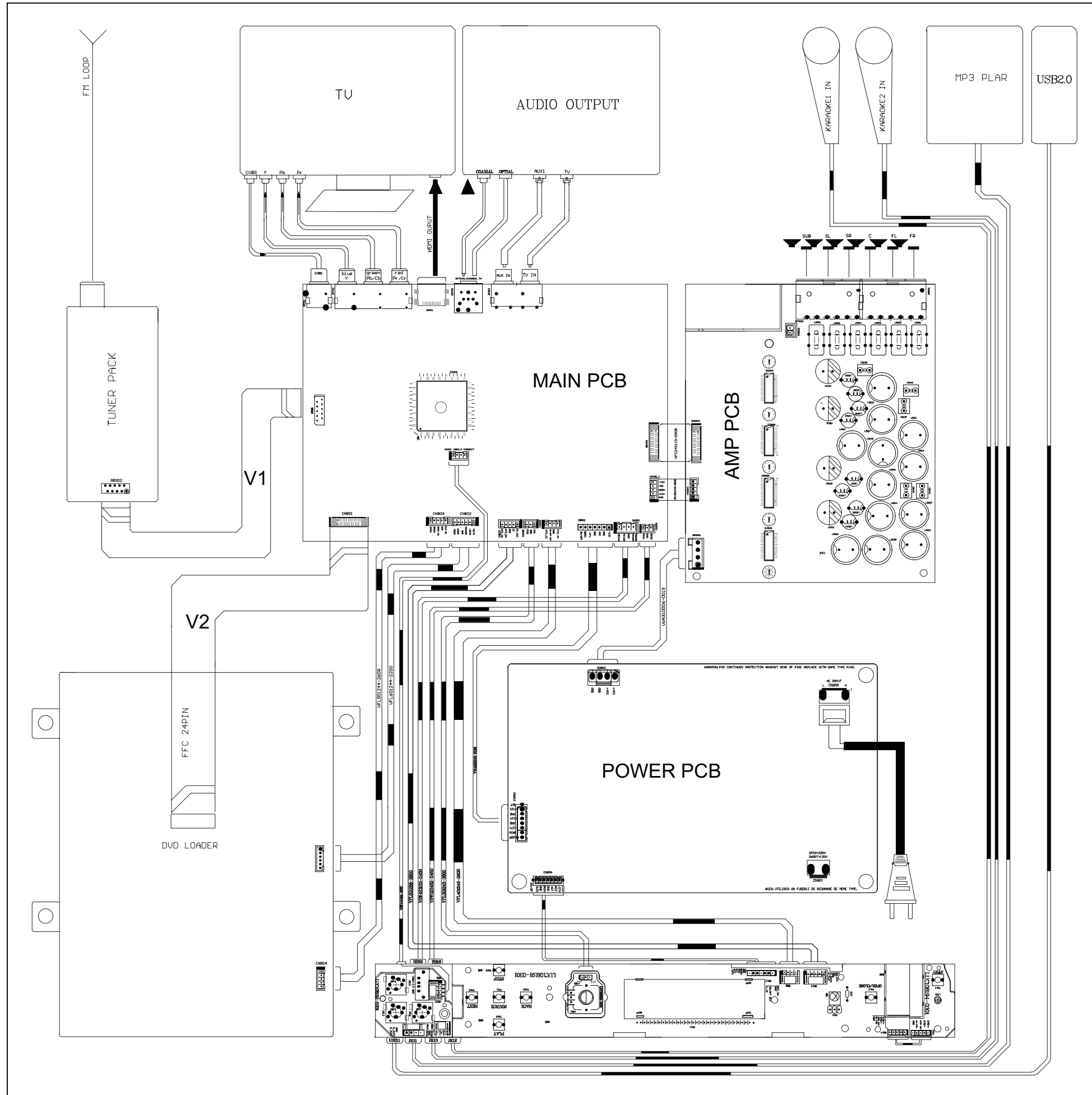

FTD DISPLAY PIN ASSIGNMENT

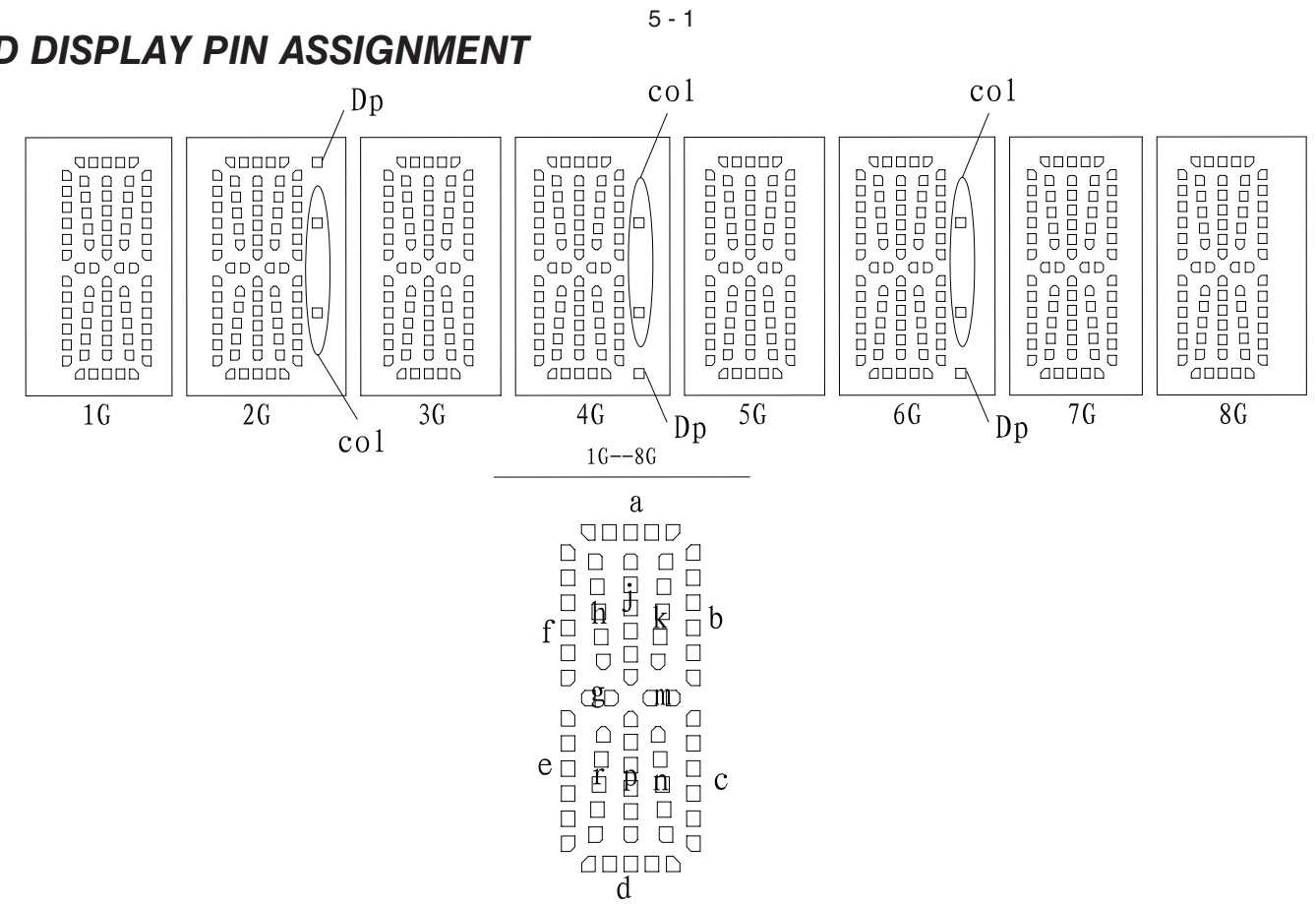

VFD+JACK+VOL+STANDBY BOARD

TABLE OF CONTENTS

FTD Display Pin Assignment.....5-1
 Circuit Diagram5-2
 PCB Layout Top & Bottom View.....5-3

	1G	2G	3G	4G	5G	6G	7G	8G
P1	a	a	a	a	a	a	a	a
P2	j, p	j, p	j, p	j, p	j, p	j, p	j, p	j, p
P3	h	h	h	h	h	h	h	h
P4	k	k	k	k	k	k	k	k
P5	b	b	b	b	b	b	b	b
P6	f	f	f	f	f	f	f	f
P7	m	m	m	m	m	m	m	m
P8	g	g	g	g	g	g	g	g
P9	c	c	c	c	c	c	c	c
P10	e	e	e	e	e	e	e	e
P11	r	r	r	r	r	r	r	r
P12	n	n	n	n	n	n	n	n
P13	d	d	d	d	d	d	d	d
P14	/	col	/	col	/	col	/	/
P15	/	Dp	/	Dp	/	Dp	/	/

PIN CONNECTION

管脚序号 (Pin NO.)	1	2	3	4	5	6	7	8	9	10	11	12	13	14	15	16
连接 (Connection)	F1	F1	NP	NC	P15	P14	NC	P13	P12	P11	P10	P9	P8	P7	P6	P5
管脚序号 (Pin NO.)	17	18	19	20	21	22	23	24	25	26	27	28	29	30	31	32
连接 (Connection)	P4	P3	P2	P1	NC	1G	2G	3G	4G	5G	6G	7G	8G	NP	F2	F2

注 (Notes) : Fn : 灯丝 (Filament Pin) nG : 栅极 (Grid Pin)
 Pn : 阳极 (Anode Pin) NP : 无引出脚 (No Pin)
 NC : 无功能 (No connection Pin)

CIRCUIT DIAGRAM

C11 B2 C15 D4 C19 B2 C23 B3 FB13 D4 FB17 D3 JK13 D2 Q16 A1 R14 B1 R18 C1 R22 C2 R27 A1 R31 C2 R35 C2 R40 A3 R46 B1 RB14 A1 RB19 D3 TA13 C1 TA20 D2
 C12 B1 C16 C1 C20 B2 DP11 A3 FB14 D3 IC11 B3 LD11 A1 R11 B1 R15 B1 R19 C1 R23 C1 R28 A1 R32 C2 R37 D1 R41 A4 RB11 B1 RB15 C4 SN11 B1 TA14 A1 USB11 C3
 C13 B1 C17 C1 C21 A3 FB11 C3 FB15 D3 JK11 C2 Q11 B1 R12 B1 R16 B1 R20 C2 R24 C2 R29 B2 R33 C2 R38 B2 R42 D3 RB12 B1 RB16 C3 TA11 C1 TA15 D2 VR11 A2
 C14 B2 C18 C1 C22 A4 FB12 C3 FB16 D3 JK12 D2 Q12 D1 R13 A1 R17 C1 R21 C1 R25 C1 R30 C2 R34 C2 R39 B2 R43 D3 RB13 C1 RB17 A2 TA12 C1 TA18 D2

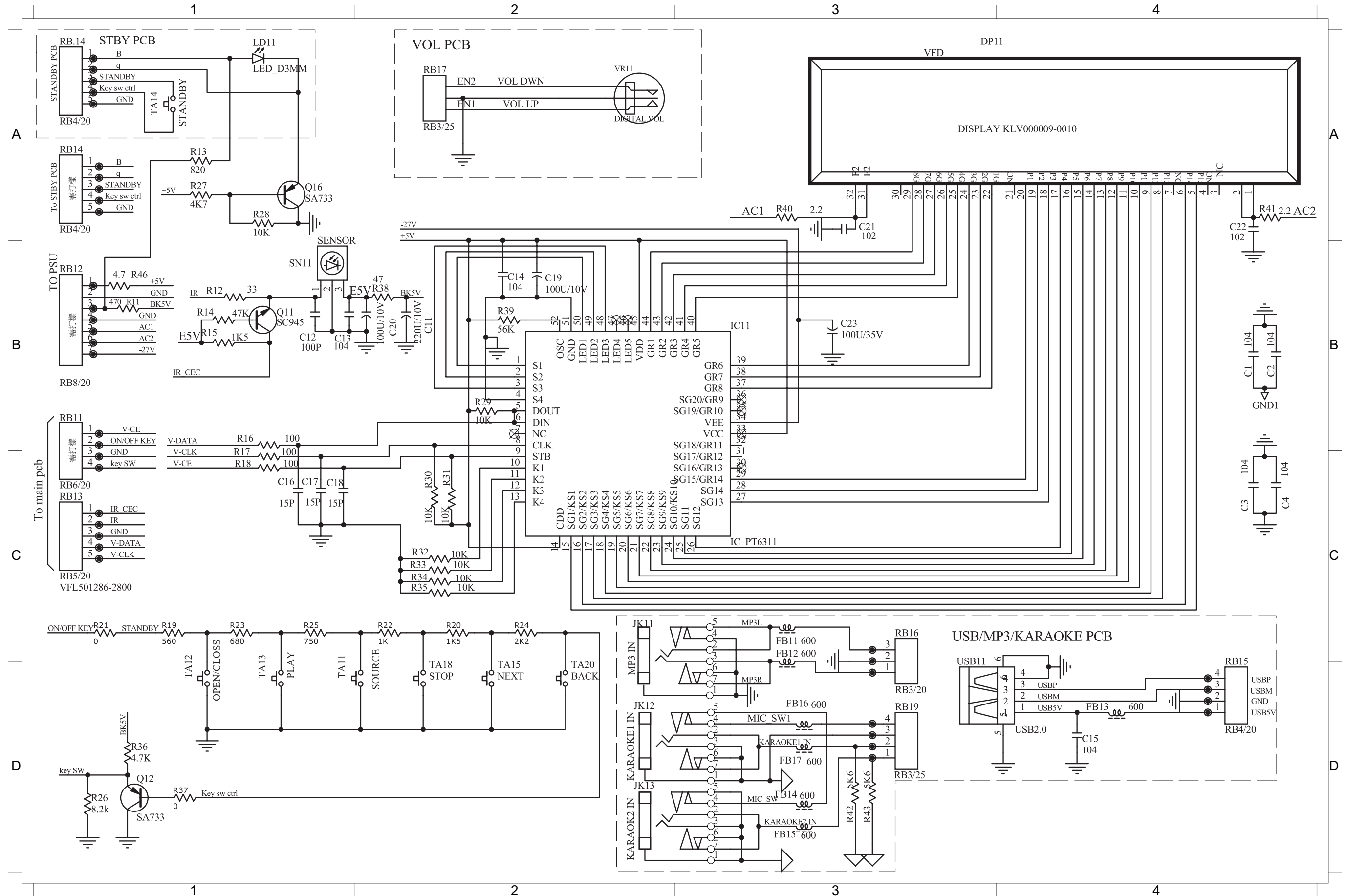

PCB LAYOUT - TOP VIEW

C11 A2 C20 A1 DP11 A2 J12 A1 J14 A1 J16 A2 J19 A2 J21 A3 J30 A1 JK12 A4 LD11 A1 R12 A1 R16 A2 R18 A2 R27 A1 R40 A2 R46 A2 RB12 A2 RB14 A1 RB16 A4 RB19 A4 TA11 A4 TA13 A4 TA15 A4 TA20 A3 VR11 A3
 C19 A2 C23 A3 J11 A1 J13 A1 J15 A1 J17 A2 J20 A3 J22 A4 JK11 A4 JK13 A4 R11 A2 R13 A2 R17 A2 R21 A2 R37 A2 R41 A2 RB11 A2 RB13 A1 RB15 A4 RB17 A3 SN11 A1 TA12 A1 TA14 A1 TA18 A4 USB11A4

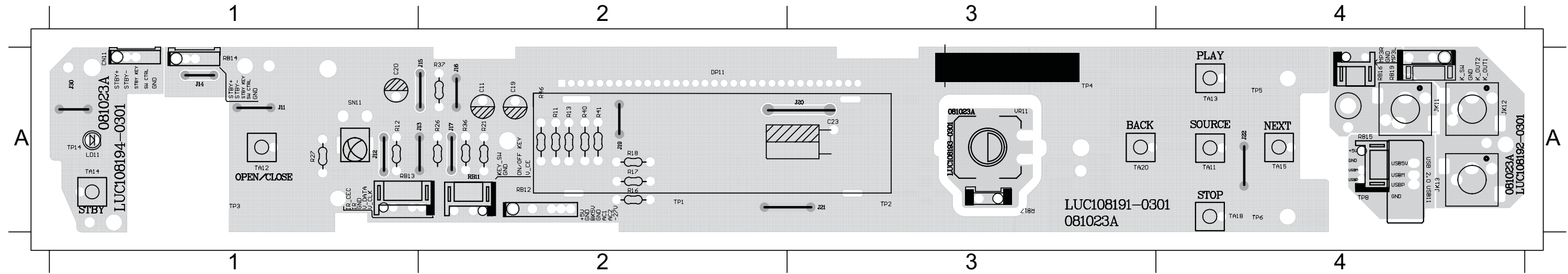

PCB LAYOUT - BOTTOM VIEW

C12 A4 C14 A3 C16 A3 C18 A3 C22 A3 FB12 A1 FB14 A1 FB16 A1 IC11 A3 Q12 A3 R14 A4 R19 A4 R22 A1 R24 A1 R28 A4 R30 A3 R32 A3 R34 A3 R38 A4 R42 A1 TP1 A3 TP8 A1
 C13 A4 C15 A1 C17 A3 C21 A2 FB11 A1 FB13 A1 FB15 A1 FB17 A1 Q11 A4 Q16 A4 R15 A4 R20 A1 R23 A1 R25 A1 R29 A3 R31 A3 R33 A3 R35 A3 R39 A3 R43 A1 TP2 A2 TP9 A1

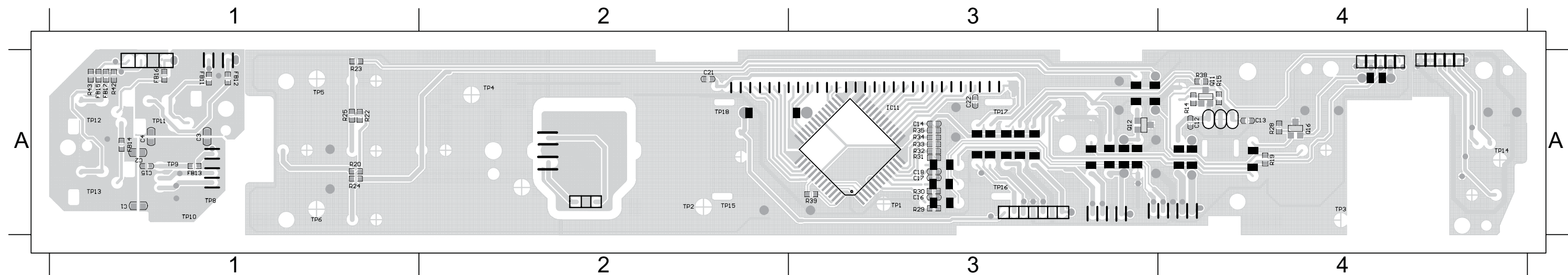

MAIN BOARD

TABLE OF CONTENTS

Internal IC Diagram6-1
 Circuit Diagram(part one)6-2
 Circuit Diagram(part two).....6-3
 PCB Layout Top View6-4
 PCB Layout Bottom View6-5

INTERNAL IC DIAGRAM - MT1389S

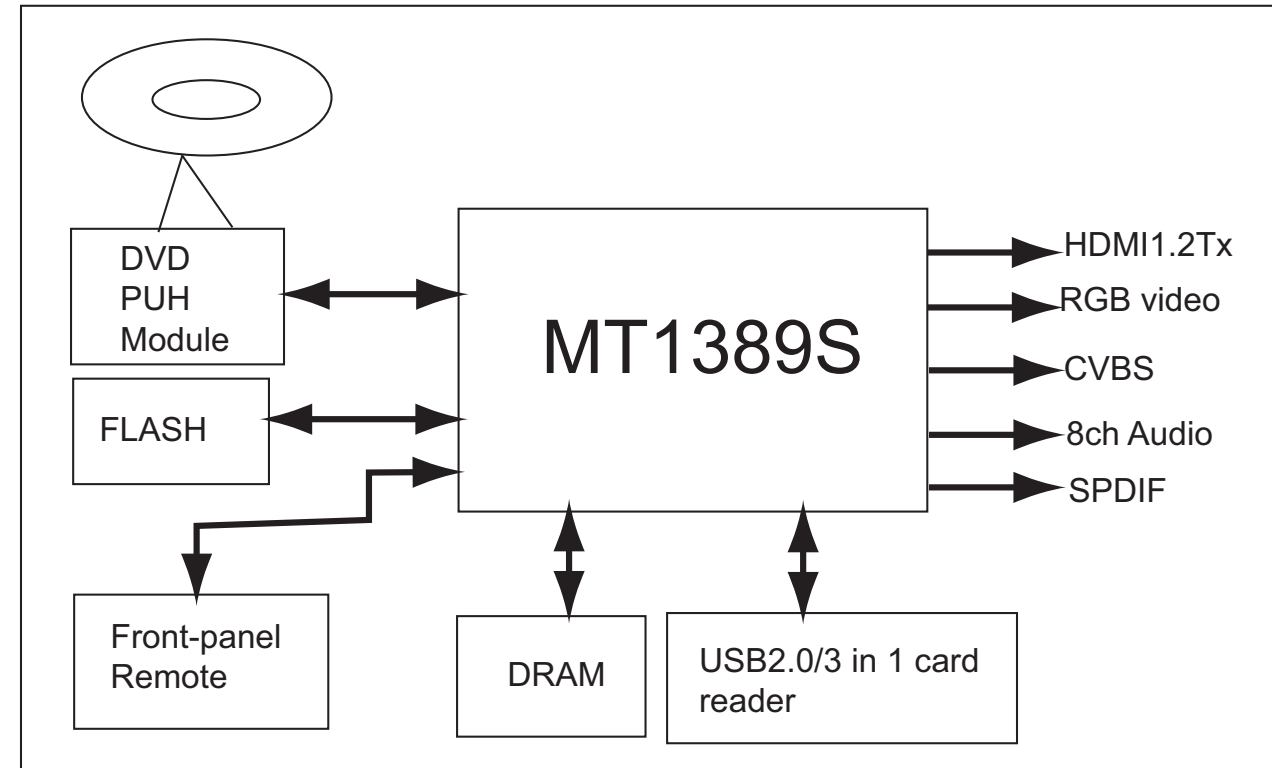

INTERNAL IC DIAGRAM - HY57V641620F

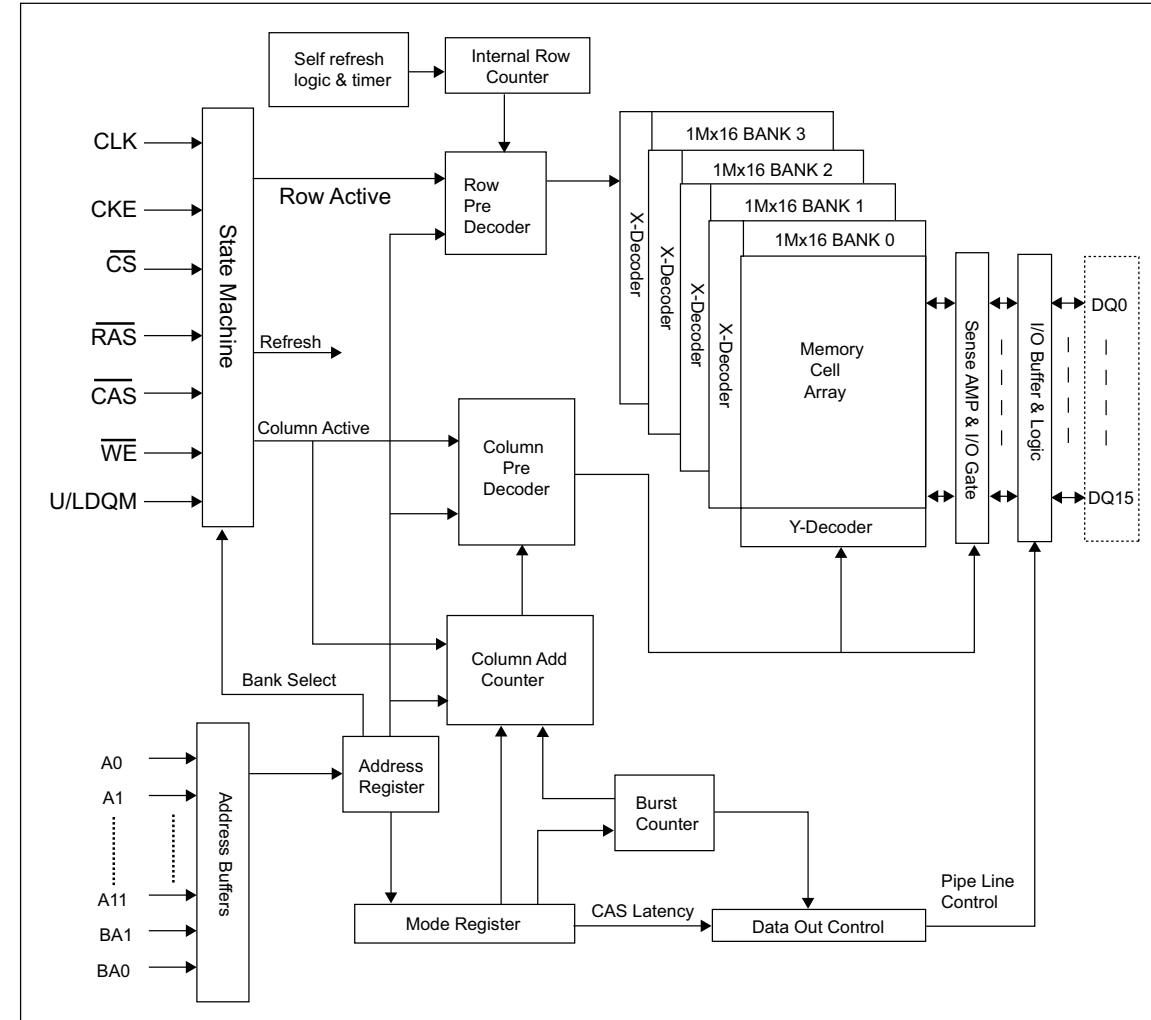

CIRCUIT DIAGRAM - part two

C0201	C2	C0216	D1	C0239	D4	C0602	C4	C213	C1	C229	C1	C257	D1	C709	A3	C737	A3	C816	B2	C831	B2	CE201	D1	CE802	D1	CN802	B1	FB207	D4	FB601	A3	IC204	D2	L204	D4	Q206	D1	Q803	A2	R211	C4	R227	D2	R247	D2	R267	D2	R288	D2	R605	B4	R802	A1	R823	A2	R845	C2
C0202	A2	C0217	D1	C0240	D4	C0603	C4	C214	C2	C230	D2	C260	D2	C710	A3	C738	C2	C817	B2	C832	B2	CE202	D1	CE803	D1	CN803	B1	FB208	D4	FB602	C4	IC205	A2	L205	B4	Q300	D3	Q804	A2	R212	C4	R228	D1	R248	C1	R268	D1	R289	D1	R701	A3	R803	A1	R824	A2	RA201	C2
C0203	A2	C0218	D1	C0241	D4	C0604	C4	C215	A2	C231	D2	C261	D1	C711	A3	C801	A1	C818	A2	C833	B3	CE203	D1	CE804	D1	C0254	A2	FB209	C1	FB603	C4	IC206	A2	L206	B3	Q602	A3	Q805	A1	R213	D2	R229	D1	R249	C1	R269	D1	R290	C1	R702	A3	R804	B1	R826	B1	RA202	C4
C0204	D1	C0219	D1	C0242	D4	C0606	C4	C216	B2	C232	C1	C600	C4	C713	A3	C802	A2	C819	B1	C834	B1	CE204	D1	CE805	D1	D201	A3	FB210	C1	FB703	A3	IC207	D3	L207	B4	Q609	B4	Q901	C1	R215	D2	R230	C1	R250	D3	R270	D2	R291	C1	R703	A3	R805	B1	R827	B1	RA203	C2
C0205	A2	C0220	D1	C0243	D4	C201	A2	C217	A2	C233	C1	C601	C4	C716	B3	C803	B1	C820	B2	C835	A1	CE205	D1	CE806	D1	D202	D1	FB211	C1	FB704	A3	IC208	D2	L701	B3	Q610	B4	R200	D1	R216	D2	R231	C1	R251	C1	R271	D1	R292	C1	R704	A3	R806	C2	R829	B1	XL201	B3
C0206	A2	C0221	D1	C0244	A2	C202	B4	C218	B4	C237	B3	C602	C4	C717	B3	C804	A2	C821	B2	C836	A2	CE206	D1	CE807	D1	D204	A3	FB212	C1	FB705	A3	IC209	B3	L702	B3	Q705	A3	R201	C4	R217	D1	R232	C1	R252	C1	R272	D2	R293	D2	R706	A4	R807	C2	R831	B2	XL202	D1
C0207	A3	C0222	D1	C0245	A2	C203	A2	C219	A3	C238	B3	C603	B4	C718	B3	C805	B1	C822	B2	C837	A2	CE207	D1	CE808	D1	D205	D3	FB213	C1	FB706	A3	IC210	A3	L703	B3	Q706	A3	R202	B4	R218	D2	R233	D2	R253	C1	R276	D2	R294	B3	R731	B3	R808	A1	R833	B2	XL203	C1
C0208	A3	C0226	D1	C0246	A2	C204	B2	C220	A3	C239	D4	C701	A3	C719	B3	C806	B1	C823	B2	C838	B2	CE212	D1	CE809	D1	D600	D1	FB214	C1	FB707	C2	IC801	B1	L704	B3	Q707	A3	R203	D1	R219	A3	R234	C1	R256	D1	R277	D2	R295	D1	R732	B3	R812	A1	R834	B2	ZD209	B4
C0209	A2	C0227	C2	C0247	A2	C205	C4	C221	B4	C242	B3	C702	A3	C720	B3	C807	B1	C824	B2	C839	B2	CE215	C2	CN201	B4	F201	B4	FB216	C2	FB708	C2	JK601	B4	L707	A3	Q708	A3	R204	D1	R220	C4	R235	B2	R257	D1	R278	D2	R296	D1	R733	B3	R813	A1	R835	B2		
C0210	B4	C0228	D1	C0248	B4	C206	B3	C223	D1	C243	D2	C703	A3	C721	B3	C808	B2	C825	B2	C840	B2	CE216	C2	CN202	C1	FB201	A2	FB217	A2	FB801	A1	JK701	A3	L801	A2	Q713	B3	R205	C1	R221	C4	R236	B2	R258	D1	R279	C1	R297	D1	R734	B3	R814	A2	R836	B1		
C0211	A2	C0229	D1	C0249	A2	C207	D3	C224	D1	C250	D1	C704	A3	C722	B3	C809	B2	C826	B2	C841	B2	CE217	C2	CN204	D2	FB202	A2	FB220	C1	FB802	A1	JK702	A3	L802	A2	Q714	B4	R206	D1	R222	D3	R237	C1	R259	D2	R280	B3	R298	D4	R737	A3	R815	A2	R838	B2		
C0212	C2	C0230	D1	C0251	C4	C208	A2	C225	C1	C253	C1	C705	A3	C723	B3	C810	A2	C827	B2	C843	B1	CE218	C2	CN205	C1	FB203	A2	FB222	C1	FB803	B1	JK703	A3	L803	B2	Q715	B4	R207	A3	R223	D3	R238	D4	R260	D2	R281	D3	R299	D4	R738	C2	R816	A1	R839	B2		
C0213	C4	C0235	D2	C0252	C4	C209	B3	C226	C1	C254	D3	C706	A3	C732	A4	C811	A2	C828	B2	C844	B2	CE219	C2	CN206	B4	FB204	A2	FB224	D4	IC201	C1	L201	A2	Q201	D4	Q716	B3	R208	D2	R224	D3	R239	D3	R261	D2	R285	D2	R601	D1	R748	A3	R817	B2	R840	B2		
C0214	C4	C0237	D4	C0253	B4	C210	C2	C227	C1	C255	C1	C707	A3	C735	C2	C812	A2	C829	B2	C846	C2	CE220	C2	CN208	C1	FB205	C4	FB225	D4	IC202	C4	L202	A2	Q204	A3	Q801	A1	R209	B4	R225	B4	R242	D1	R263	D2	R286	D2	R603	C4	R751	A3	R820	A1	R841	B2		
C0215	C2	C0238	D4	C0601	C4	C211	D4	C228	C2	C256	D1	C708	A3	C736	A3	C813	B2	C830	B2	C849	B2	CE801	D1	CN801	A1	FB206	C4	FB226	A2	IC203	D3	L203	A2	Q205	D1	Q802	A1	R210	C4	R226	D1	R245	C1	R264	D2	R287	D2	R604	B4	R752	A3	R822	A2	R842	B2		

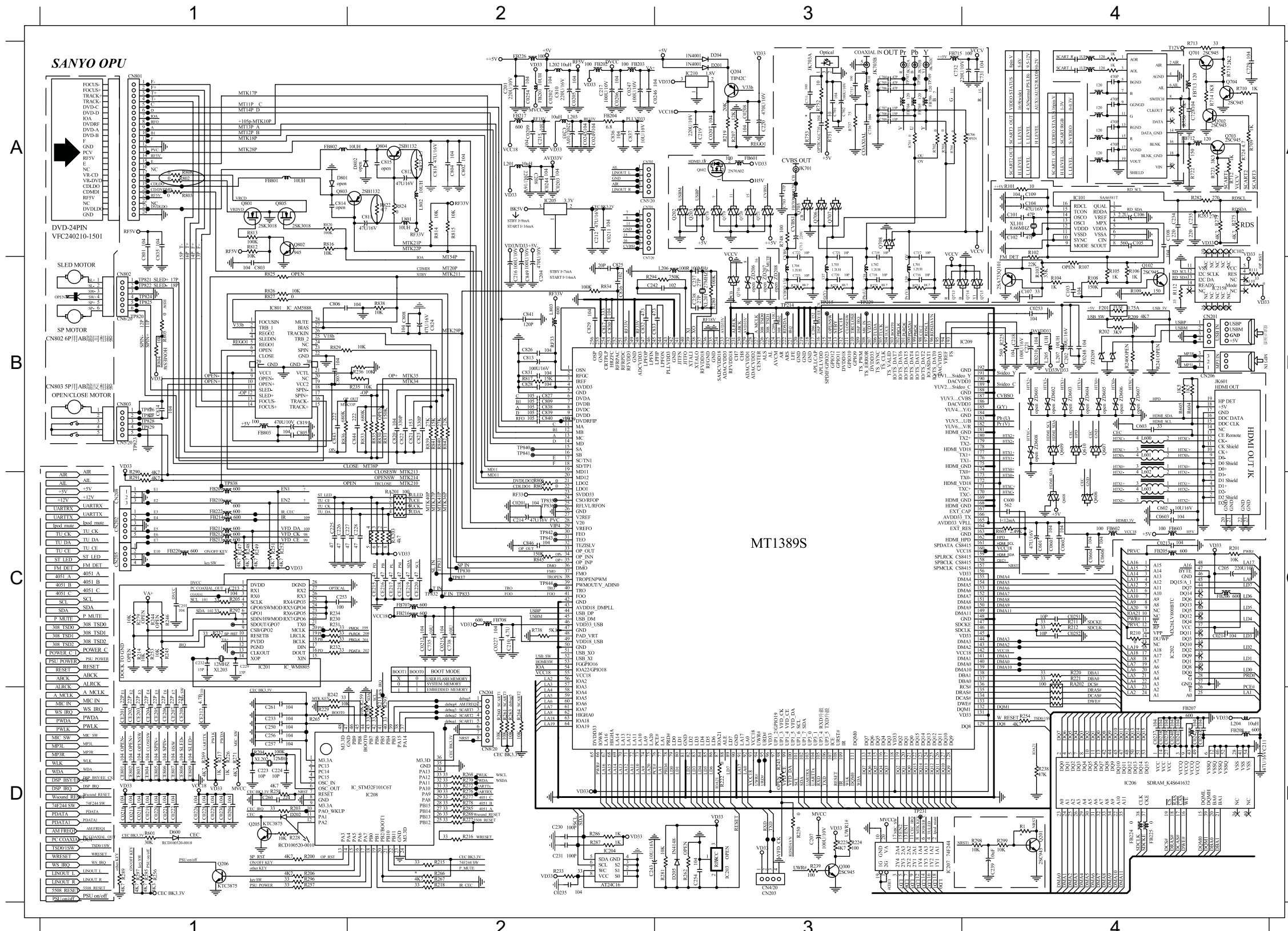

PCB LAYOUT - TOP VIEW

C0202	A2	C216	C3	C257	C3	C325	B3	C350	C4	C602	A2	C720	B1	C818	D1	C841	C1	CN201	C2	D600	C3	FB224	A2	FB905	D4	IC309	B1	L701	A2	Q610	A2	R208	C3	R227	D3	R252	C3	R280	B1	R3002	C4	R313	B3	R341	B4	R359	B3	R389	B3	R537	D4	R731	A2	R814	D1	R840	C2	XL501	C4
C0207	C2	C217	B1	C260	C3	C326	B3	C351	C4	C603	A2	C721	A2	C819	D1	C843	D2	CN202	D2	F201	C2	FB225	A2	FE312	A2	IC501	C4	L702	A2	Q706	A1	R209	C2	R228	D3	R253	B1	R281	B3	R3003	B4	R314	A3	R342	B4	R360	B3	R390	B3	R549	C4	R732	A2	R815	D1	R841	C2	ZD209	C2
C0208	D2	C218	B2	C261	C3	C329	B3	C352	A3	C701	A3	C722	A1	C820	C2	C844	D2	CN204	D3	FB201	C3	FB226	D1	IC201	B1	IC801	D2	L703	A2	Q707	A1	R210	C3	R229	C3	R257	D3	R285	D3	R3006	C4	R317	B3	R343	B3	R361	C4	R501	D4	R550	C4	R733	B1	R816	C1	R842	C2	ZD301	B4
C0211	D3	C219	C2	C3001	C4	C330	B3	C353	A4	C702	A2	C723	B1	C821	C2	C849	C1	CN205	D3	FB202	B1	FB310	B3	IC202	C3	JK302	A3	L704	B1	Q708	A1	R211	A2	R230	B1	R258	C3	R286	B3	R3007	C4	R318	B3	R344	B4	R364	B4	R502	D4	R552	C4	R734	B1	R817	C2	R845	D2	ZD302	B4
C0235	B3	C220	C2	C3002	B4	C331	B3	C354	A3	C703	A1	C732	B1	C822	C2	C912	C3	CN206	D4	FB203	B1	FB311	D2	IC203	B3	JK601	A2	L707	A1	Q801	C1	R212	A2	R231	B2	R259	C3	R287	B3	R3008	C4	R321	B3	R345	A3	R365	B4	R504	D4	R553	C4	R737	A1	R820	C1	R903	C3	ZD901	D4
C0247	B1	C221	B2	C3003	C4	C334	B4	C355	B3	C704	A2	C736	A1	C823	D2	C918	B4	CN208	D3	FB205	C3	FB312	A4	IC204	B3	JK701	A1	L801	A1	Q802	C1	R213	C3	R232	B1	R260	D3	R288	D3	R3009	B4	R322	B3	R346	A3	R366	B4	R505	D4	R554	C4	R738	C2	R822	D1	R904	D3	ZD904	C1
C201	C1	C229	B1	C3004	C4	C335	B4	C356	A3	C705	A1	C737	A2	C824	C2	C919	B4	CN301	B1	FB206	B3	FB313	B3	IC205	D3	JK702	A1	L802	D1	Q803	D1	R215	D3	R233	B3	R261	C3	R289	D3	R301	B1	R325	B3	R347	B4	R367	B4	R506	D4	R556	C4	R748	A1	R823	D1	R911	D4		
C202	B1	C230	B3	C3005	C4	C336	B4	C357	A3	C706	A1	C801	D1	C825	C2	C920	C2	CN303	D4	FB207	B3	FB601	A2	IC206	B3	JK703	A2	L803	C2	Q804	D1	R216	B4	R234	B1	R263	C3	R290	D2	R3010	C4	R326	B3	R348	A3	R368	B3	R507	D4	R558	C4	R751	A2	R824	D1	R913	C1		
C203	C1	C231	B3	C3006	B4	C337	A4	C359	B4	C707	A1	C803	C1	C827	C2	C921	B1	CN401	D4	FB208	B3	FB603	A2	IC207	C3	L201	B1	Q204	D2	Q805	C1	R217	B4	R235	D2	R267	D3	R291	D2	R3011	B4	R329	B4	R349	A3	R369	A4	R509	D4	R560	C4	R752	A2	R826	C1	R924	C1		
C204	D3	C232	B1	C3007	B4	C338	B4	C360	B4	C708	A1	C805	D2	C829	C1	C922	C1	CN801	D1	FB209	D3	FB703	A1	IC208	C3	L202	D1	Q205	D3	Q901	C1	R218	D3	R236	D2	R268	C3	R292	B1	R3018	B1	R330	B4	R350	A3	R371	B4	R512	D4	R601	C3	R802	C1	R827	C2	R928	B4		
C205	C3	C237	C2	C3008	B4	C339	B4	C362	C3	C709	A1	C806	C2	C830	C1	C928	D3	CN802	D2	FB210	D3	FB704	A2	IC209	B2	L203	C2	Q206	D3	Q903	D4	R219	D2	R237	B1	R269	A3	R293	C3	R302	B3	R331	B3	R351	A3	R372	B4	R513	D4	R603	B2	R803	C1	R829	C2	R929	B4		
C207	C3	C238	B1	C301	A3	C340	B3	C363	C4	C710	A2	C809	C2	C831	C1	C929	B4	CN803	D2	FB211	D3	FB705	A1	IC210	D2	L204	A3	Q300	C3	R200	D2	R220	A2	R242	C3	R270	C3	R294	B2	R3031	B4	R332	B4	R352	A4	R373	B4	R515	D4	R604	A2	R804	C2	R831	D2	RA201	B2		
C208	B2	C239	A2	C302	A3	C341	B4	C364	B4	C711	A2	C810	D1	C832	C1	C932	D4	D201	D2	FB212	D3	FB706	A1	IC3001	C4	L205	B2	Q302	B4	R201	C2	R221	A2	R245	B1	R271	C3	R295	D3	R3036	B4	R334	C3	R353	B3	R379	B4	R518	D4	R605	A2	R805	D2	R833	D2	RA202	A2		
C210	C2	C242	C2	C316	B3	C342	B4	C365	B4	C713	A1	C811	D1	C833	C1	C935	C3	D202	D3	FB213	D3	FB708	C2	IC301	A3	L206	C1	Q303	B4	R202	C2	R222	B3	R247	D3	R272	C3	R296	D3	R305	B1	R335	C4	R354	A3	R380	B4	R519	D4	R701	A1	R806	D1	R834	C1	RB403	C4		
C211	A3	C243	B3	C317	B1	C343	B3	C365	C4	C716	A2	C812	D1	C834	D2	C936	C3	D204	D2	FB214	D3	FB801	D1	IC303	A4	L207	B1	Q304	B4	R203	C3	R223	C3	R248	D3	R276	C3	R297	D3	R307	C4	R336	C4	R355	A3	R381	B4	R520	D4	R702	A1	R807	D1	R835	D2	RB901	D3		
C213	B1	C253	B1	C320	C4	C344	B4	C516	D4	C717	A2	C813	C2	C838	C2	CE901	C1	D205	C3	FB217	B1	FB802	D1	IC304	B3	L501	C3	Q305	A1	R205	B1	R224	C3	R249	D3	R277	C3	R298	A2	R308	B1	R337	B4	R356	A3	R382	B4	R521	D4	R703	A1	R808	D1	R836	D2	XL201	B1		
C214	C2	C254	C3	C321	B3	C346	B4	C517	C4	C718	A2	C816	C1	C839	C2	CE903	B3	D302	B4	FB220	D3	FB803	D1	IC305	B3	L502	D3	Q602	A2	R206	D3	R225	B2	R250	B1	R278	D3	R299	A2	R309	A3	R338	A4	R357	A3	R383	B4	R522	D4	R704	A1	R812	C1	R838	C2	XL202	D3		
C215	B2	C255	B1	C322	C4	C349	C3	C601	A2	C719	A2	C817	C1	C840	C2	CE904	A2	D303	B4	FB222	D3	FB901	C1	IC306	B4	L503	C3	Q609	A2	R207	D2	R226	B4	R251	C3	R279	B1	R3001	C4	R310	B3	R340	B4	R358	A4	R384	B4	R523	C4	R706	A1	R813	C1	R839	D2	XL203	B1		

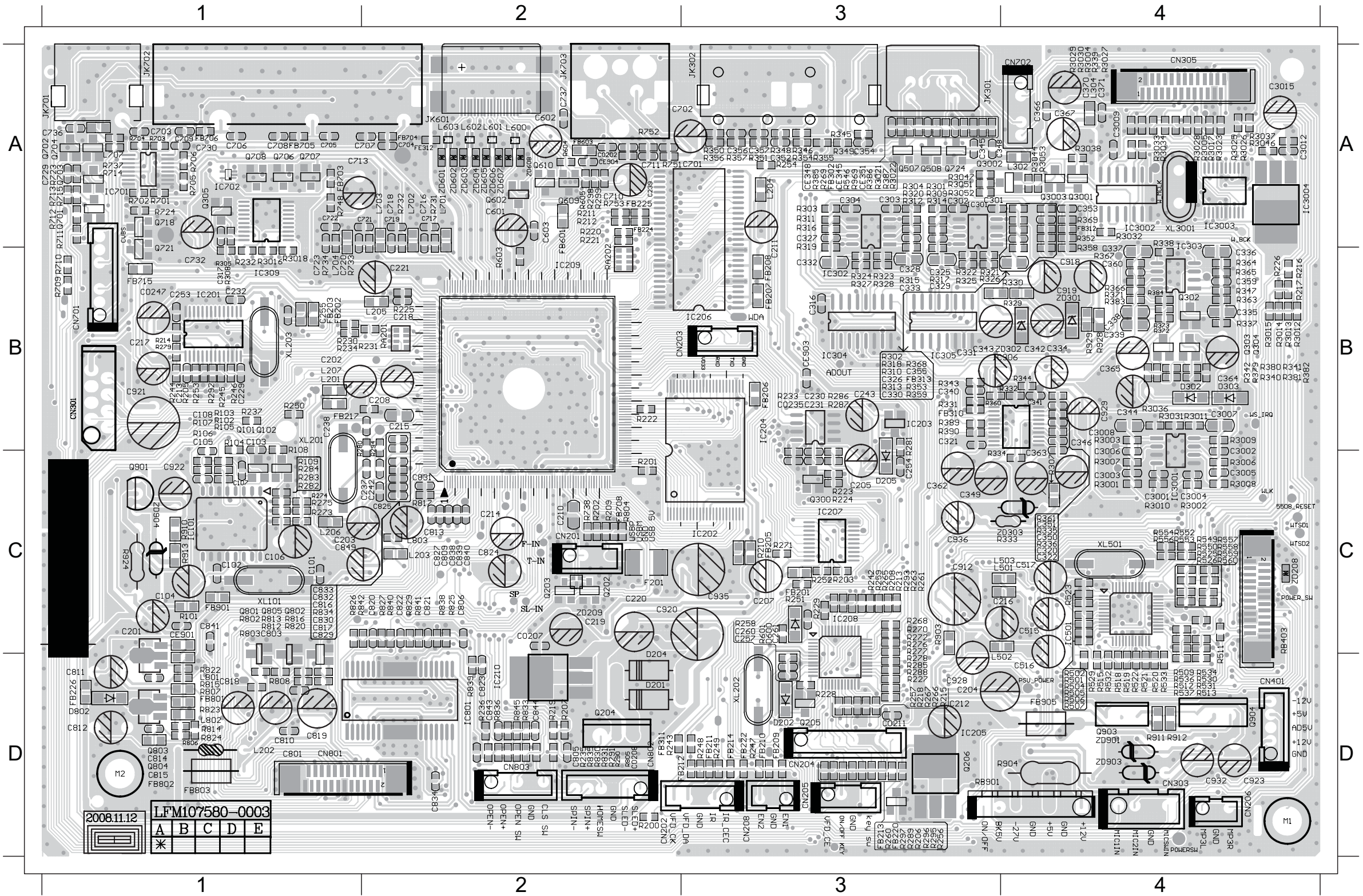

PCB LAYOUT - BOTTOM VIEW

C0201	C3	C0213	C2	C0221	B3	C0238	A2	C0246	B4	C0603	A3	C226	B4	C309	B2	C502	C1	C512	C1	C738	B3	C836	B3	C906	C4	CE204	D2	CE218	B4	CE306	D3	CE314	A1	CE322	B1	CE330	C4	CE807	D3	FE301	B3	Q201	A2	R239	C2	R503	C1
C0203	B3	C0214	B2	C0222	B3	C0239	B2	C0248	B3	C0604	B3	C227	B4	C311	B2	C503	C1	C513	C1	C802	D4	C837	B3	C907	D1	CE205	D2	CE219	B4	CE307	D2	CE315	A1	CE323	B2	CE341	B3	CE808	D3	FE302	B3	Q705	A4	R256	D2	R510	C1
C0204	B3	C0215	C3	C0226	C3	C0240	B2	C0249	C3	C0606	B3	C228	B4	C313	B2	C506	C1	C514	C1	C804	C3	C846	C3	C908	C2	CE206	D2	CE220	B4	CE308	C1	CE316	A1	CE324	B2	CE801	D3	CE809	D3	FE306	A3	Q713	A3	R264	D2	R517	D1
C0205	D4	C0216	B3	C0227	C3	C0241	A2	C0251	A3	C206	B3	C233	C2	C315	B2	C507	C1	C518	D1	C807	D3	C901	D2	C911	D1	CE207	D2	CE301	D3	CE309	C1	CE317	A2	CE325	B2	CE802	D3	CO254	C4	FE307	B3	Q714	A4	R3019	B2	R524	C1
C0206	B4	C0217	B3	C0228	B3	C0242	B3	C0252	A3	C209	B3	C250	C2	C318	B1	C508	D1	C519	D1	C808	C3	C902	D1	C924	D1	CE212	D2	CE302	D4	CE310	A1	CE318	A1	CE326	A2	CE803	D3	FB204	B3	FE308	A3	Q715	A4	R3020	B2	RA203	B3
C0209	B3	C0218	B3	C0229	B3	C0243	B3	C0253	B3	C223	D2	C256	D2	C319	B1	C509	C1	C521	D1	C826	C3	C903	D1	CE201	D2	CE215	A4	CE303	C3	CE311	C1	CE319	C1	CE327	A3	CE804	D3	FB216	C3	FE309	B3	Q716	A4	R378	B3	ZD902	D1
C0210	B3	C0219	B3	C0230	B3	C0244	B3	C0601	B3	C224	D2	C305	A2	C323	B4	C510	C1	C600	B3	C828	C3	C904	D1	CE202	D2	CE216	B3	CE304	C3	CE312	A1	CE320	B2	CE328	A4	CE805	D3	FB602	B3	FE310	A3	R204	D2	R388	B4		
C0212	C3	C0220	B3	C0237	B2	C0245	C3	C0602	A3	C225	B4	C306	A1	C324	B2	C511	C1	C735	B3	C835	D4	C905	B4	CE203	D2	CE217	B4	CE305	D3	CE313	B1	CE321	C1	CE329	B4	CE806	D3	FB707	B3	FE311	A3	R238	B2	R399	C2		

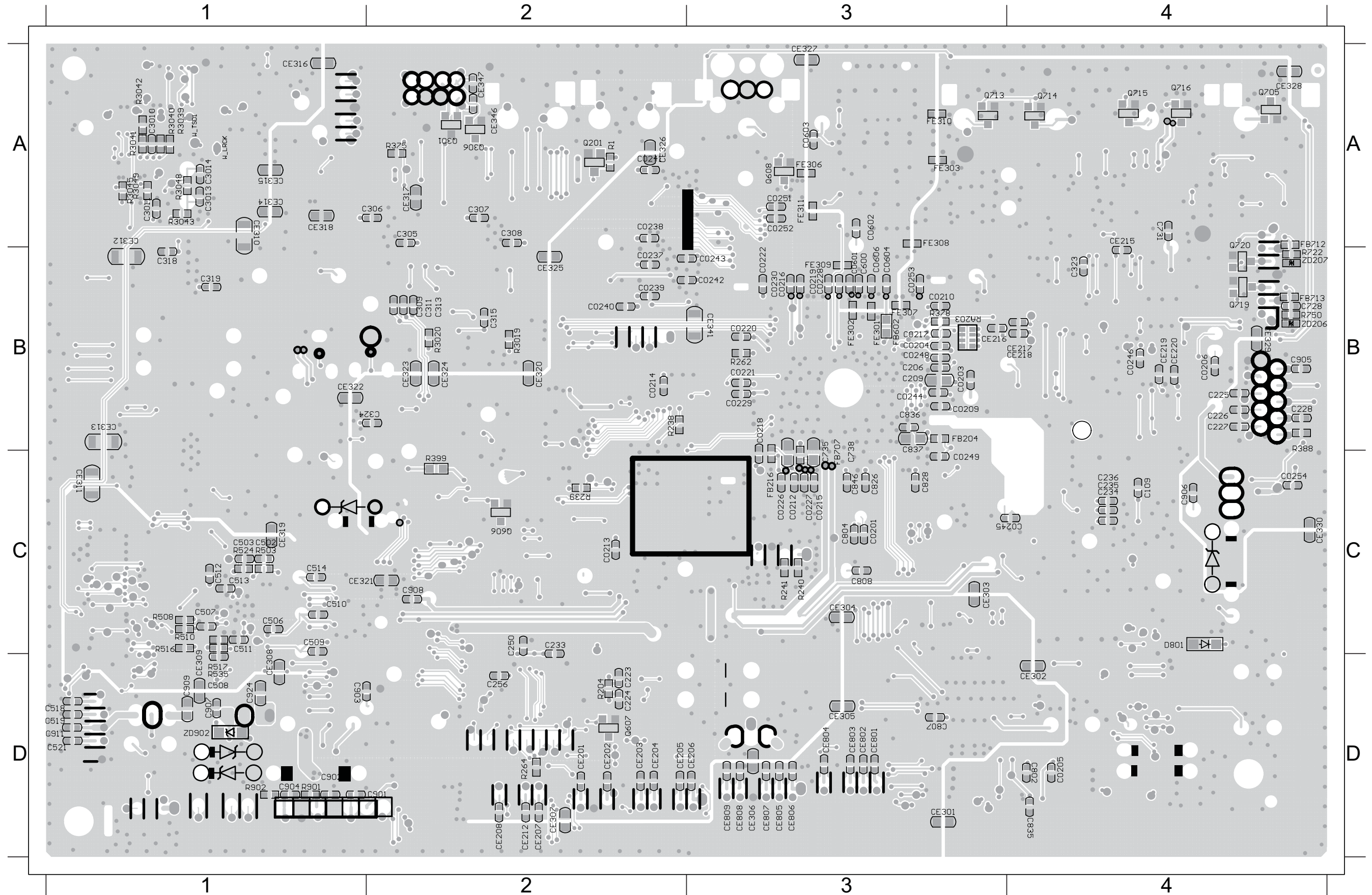

POWER BOARD

TABLE OF CONTENTS

Internal IC Diagram	7-1
Circuit Diagram.....	7-2
PCB Layout Top View	7-3
PCB Layout Bottom View	7-4

INTERNAL IC DIAGRAM - AZ431

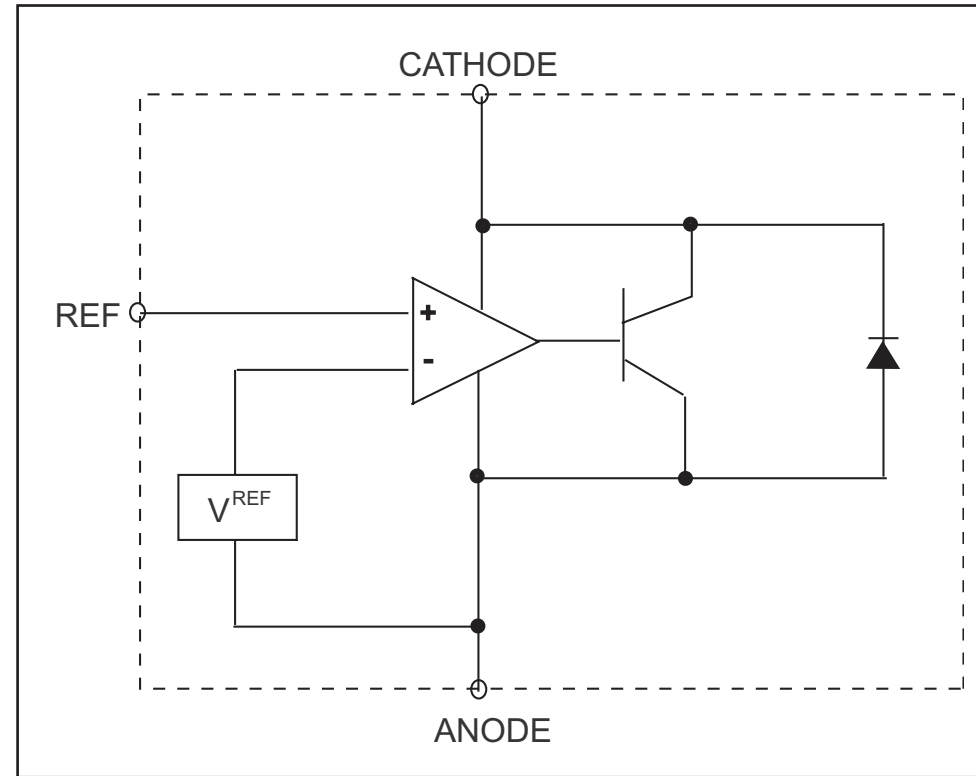

INTERNAL IC DIAGRAM - TNY180PN

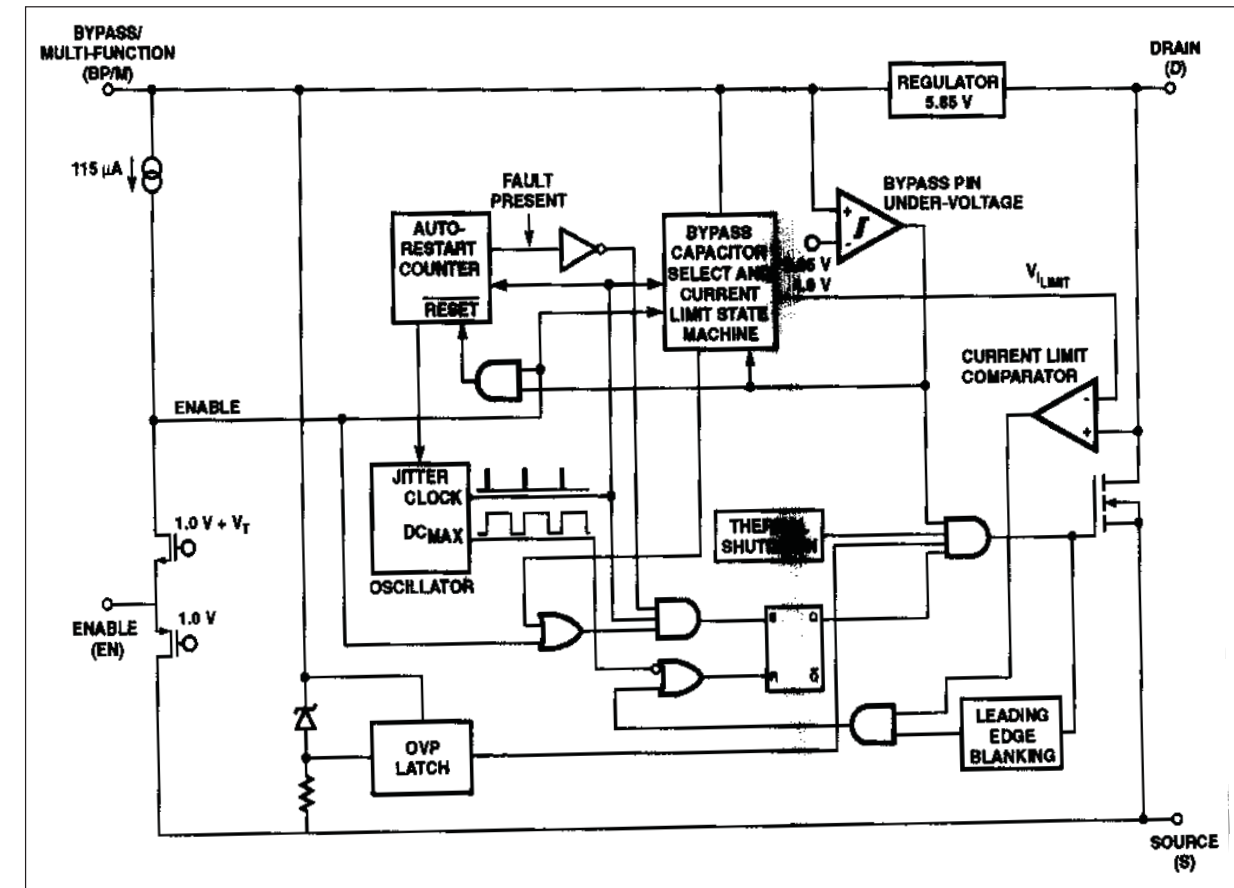

CIRCUIT DIAGRAM

BD901	A1	TVR902	A1	R908	A2	C968	A3	D916	A3	R976	A3	R952	A4	C919	B1	Q910	B2	C966	B3	R930	B3	C980	B4	F901	C1	TVR901	C1	IC903	C2	C926	C3	C946	C3	Q923	C3	C984	C4	R938	C4	C906	D1	C944	D3	R987	D3
C904	A1	TVR903	A1	R944	A2	C969	A3	J912	A3	ZD908	A3	R953	A4	GT902	B1	Q912	B2	C967	B3	R961	B3	C981	B4	J905	C1	C915	C2	J909	C2	C928	C3	D922	C3	R922	C3	C985	C4	R980	C4	C965	D1	C989	D3	R988	D3
C905	A1	C910	A2	R949	A2	C970	A3	L907	A3	ZD909	A3	R954	A4	J902	B1	R941	B2	C975	B3	R963	B3	C988	B4	NTC901	C1	C916	C2	R914	C2	C929	C3	D923	C3	R923	C3	CN903	C4	R982	C4	CN901	D1	IC904	D3	C986	D4
C908	A1	C912	A2	R950	A2	C971	A3	L908	A3	ZD912	A3	R955	A4	L901	B1	R942	B2	D907	B3	R964	B3	CN906	B4	R901	C1	C927	C2	R933	C2	C930	C3	D924	C3	R924	C3	Q906	C4	R984	C4	J904	D1	J908	D3	CN904	D4
C909	A1	C950	A2	T903	A2	C972	A3	R909	A3	C958	A4	R960	A4	L902	B1	R943	B2	D908	B3	R965	B3	D917	B4	R902	C1	C937	C2	R934	C2	C931	C3	D926	C3	R925	C3	Q921	C4	R993	C4	J906	D1	J916	D3	J914	D4
CN902	A1	C951	A2	ZD904	A2	C976	A3	R956	A3	CN905	A4	R969	A4	R912	B1	T901	B2	L905	B3	R966	B3	IC905	B4	R903	C1	C938	C2	R945	C2	C932	C3	L903	C3	R926	C3	Q922	C4	R994	C4	J907	D1	R939	D3	ZD906	D4
R915	A1	D902	A2	C952	A3	D904	A3	R971	A3	D912	A4	R970	A4	C913	B2	T902	B2	Q911	B3	R967	B3	R979	B4	R904	C1	C939	C2	R990	C2	C933	C3	L904	C3	R928	C3	Q924	C4	R995	C4	C942	D2	R940	D3		
R916	A1	D906	A2	C953	A3	D909	A3	R972	A3	D914	A4	ZD910	A4	C941	B2	ZD903	B2	Q925	B3	R968	B3	R981	B4	R905	C1	C947	C2	R991	C2	C934	C3	Q905	C3	R936	C3	R911	C4	R998	C4	IC902	D2	R946	D3		
R917	A1	J903	A2	C954	A3	D911	A3	R973	A3	D919	A4	C917	B1	D903	B2	C921	B3	R920	B3	C974	B4	ZD907	B4	R906	C1	D918	C2	ZD902	C2	C935	C3	Q918	C3	R974	C3	R935	C4	C902	D1	R947	D2	R948	D3		
R918	A1	Q913	A2	C959	A3	D913	A3	R975	A3	J919	A4	C918	B1	D905	B2	C964	B3	R921	B3	C977	B4	C907	C1	R910	C1	D920	C2	C923	C3	C936	C3	Q920	C3	C983	C4	R937	C4	C903	D1	C943	D3	R986	D3		

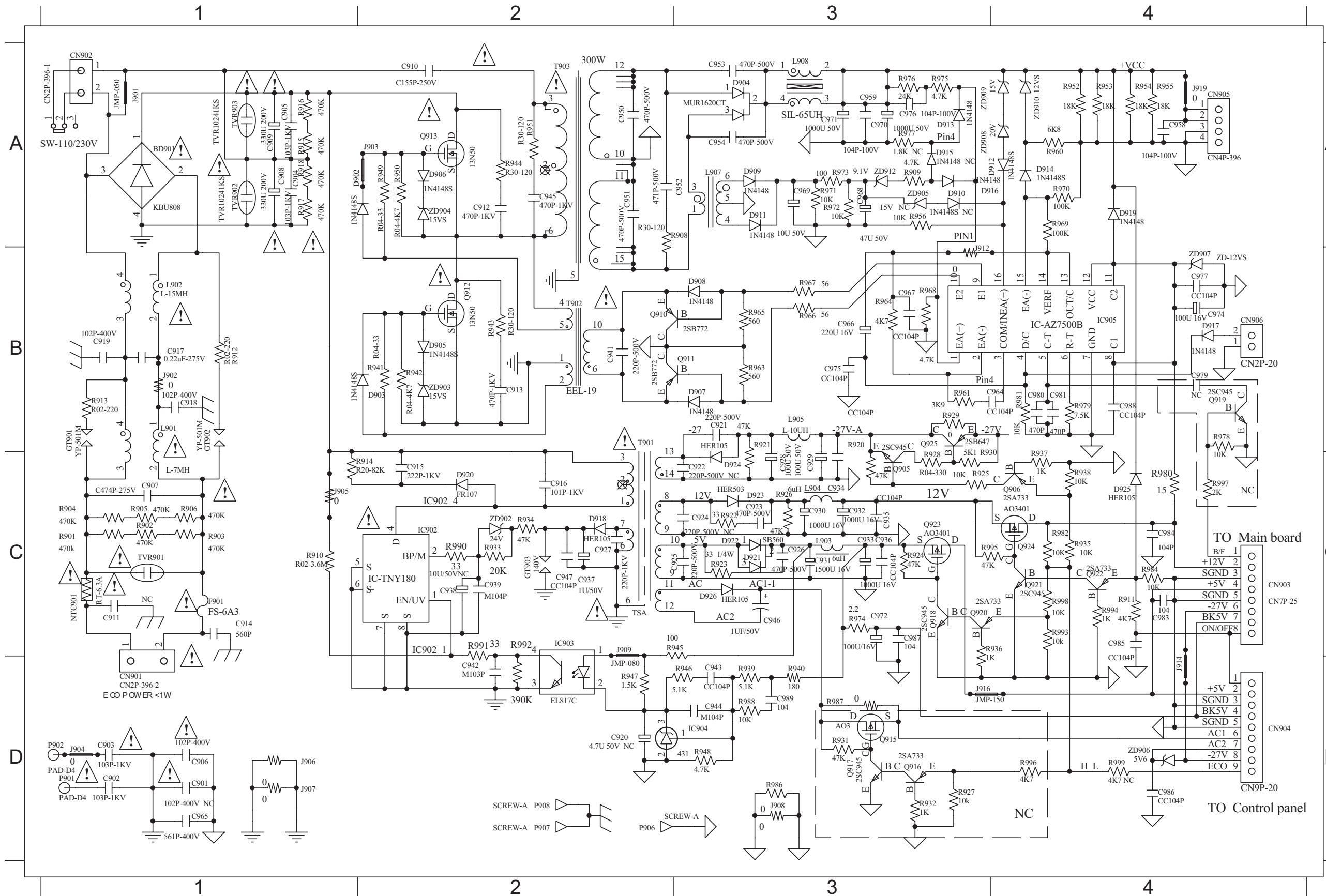

PCB LAYOUT - TOP VIEW

BD901	A1	C907	C1	C917	B1	C931	B4	C942	A2	C969	C4	CN902	A1	D903	B2	D914	C4	D923	B3	IC903	A3	J905	A2	J911	A4	J918	B4	L904	B4	Q911	C3	R912	B1	R939	A3	R945	A3	R967	B4	R988	A3	TVR903	C2		
C902	D2	C908	A1	C918	C1	C932	B4	C944	A3	C970	D4	CN903	B4	D904	D3	D916	C4	D924	A3	IC904	A3	J906	A3	J912	C4	J919	C4	L905	A3	Q912	B2	R914	A2	R940	A4	R949	A4	R949	C2	R973	C4	T901	B3	ZD902	A2
C903	A2	C909	B2	C919	D1	C933	B4	C946	A3	C971	D4	CN904	A4	D907	C3	D918	B3	D926	A3	IC905	B2	J907	C2	J913	A4	J920	A4	L907	C4	Q913	C2	R928	A4	R941	B3	R950	C2	R974	A4	T902	C3	ZD908	C4		
C904	A4	C910	B1	C928	A3	C937	B2	C965	B3	C972	A4	CN905	D4	D908	B3	D919	B4	F901	D1	J902	C1	J908	A3	J914	A4	L901	C1	L908	D4	Q925	A4	R933	A2	R942	B2	R963	C3	R975	C4	T903	D3	ZD910	C4		
C905	B2	C913	B3	C929	A3	C938	A2	C966	B4	C974	B4	CN906	C4	D912	C4	D920	A2	GT902	C1	J903	C2	J909	A3	J915	A4	L902	B1	NTC901	D1	R908	C3	R934	B2	R943	B2	R965	C3	R980	B4	TVR901	D1				
C906	A3	C915	A2	C930	B3	C939	A2	C968	C4	CN901	D1	D902	C2	D913	C4	D922	B3	IC902	A2	J904	A2	J910	A4	J916	A4	L903	B4	Q910	B3	R910	A2	R935	A4	R944	C2	R966	B4	R982	B4	TVR902	A1				

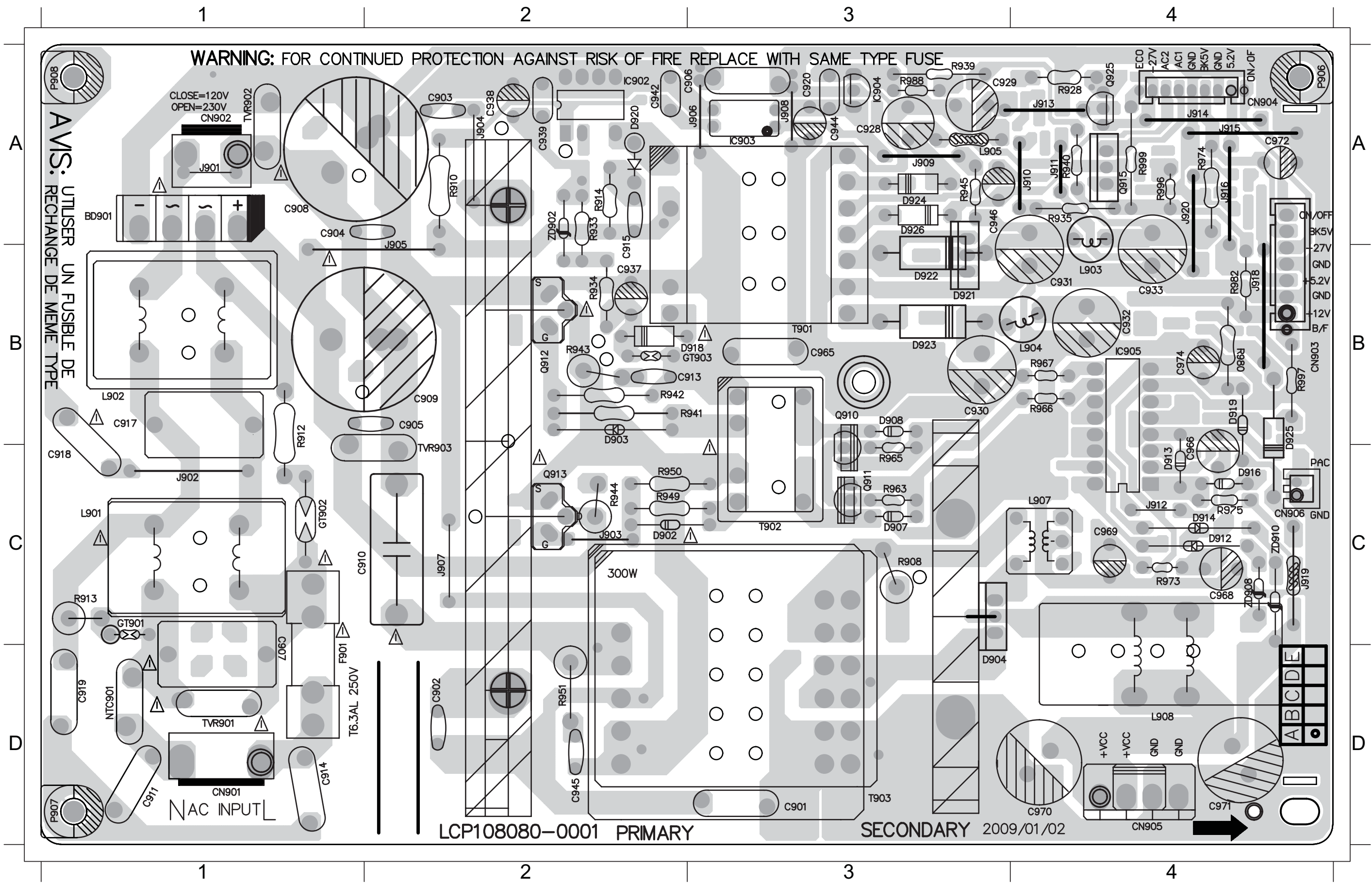

PCB LAYOUT - BOTTOM VIEW

C912	B4	C927	B3	C943	A2	C953	C2	C967	B1	C981	B1	C988	B1	D911	C1	Q920	A1	R901	D4	R906	C4	R917	A4	R923	A2	R936	A1	R948	A2	R956	C1	R969	C1	R979	B1	R990	A3	R998	A1	ZD909	C1		
C916	A3	C934	A2	C947	B4	C954	C1	C975	B1	C983	B1	C989	A2	D917	C1	Q921	B1	R902	D4	R909	C1	R918	A4	R924	A1	R937	A1	R952	D1	R960	C1	R970	C1	R981	C1	R991	A3	ZD903	B4	ZD912	C1		
C921	A2	C935	B1	C950	D2	C958	D1	C976	C1	C984	B1	D905	B4	Q905	A1	Q922	B1	R903	D4	R911	A1	R920	A2	R925	A1	R938	A1	R953	D1	R961	B1	R971	C1	R984	B1	R993	A1	ZD904	C3				
C923	B2	C936	B1	C951	C2	C959	D1	C977	B1	C985	A1	D906	C3	Q906	A1	Q923	B1	R904	C4	R915	B4	R921	A2	R926	B2	R946	A2	R954	D1	R964	C1	R972	C1	R986	A1	R994	B1	ZD906	A1				
C926	A2	C941	C2	C952	C2	C964	C1	C980	B1	C986	A1	D909	C1	Q918	A1	Q924	B1	R905	C4	R916	B4	R922	B2	R930	A1	R947	A2	R955	D1	R968	C1	R976	C1	R987	A1	R995	B1	ZD907	B1				

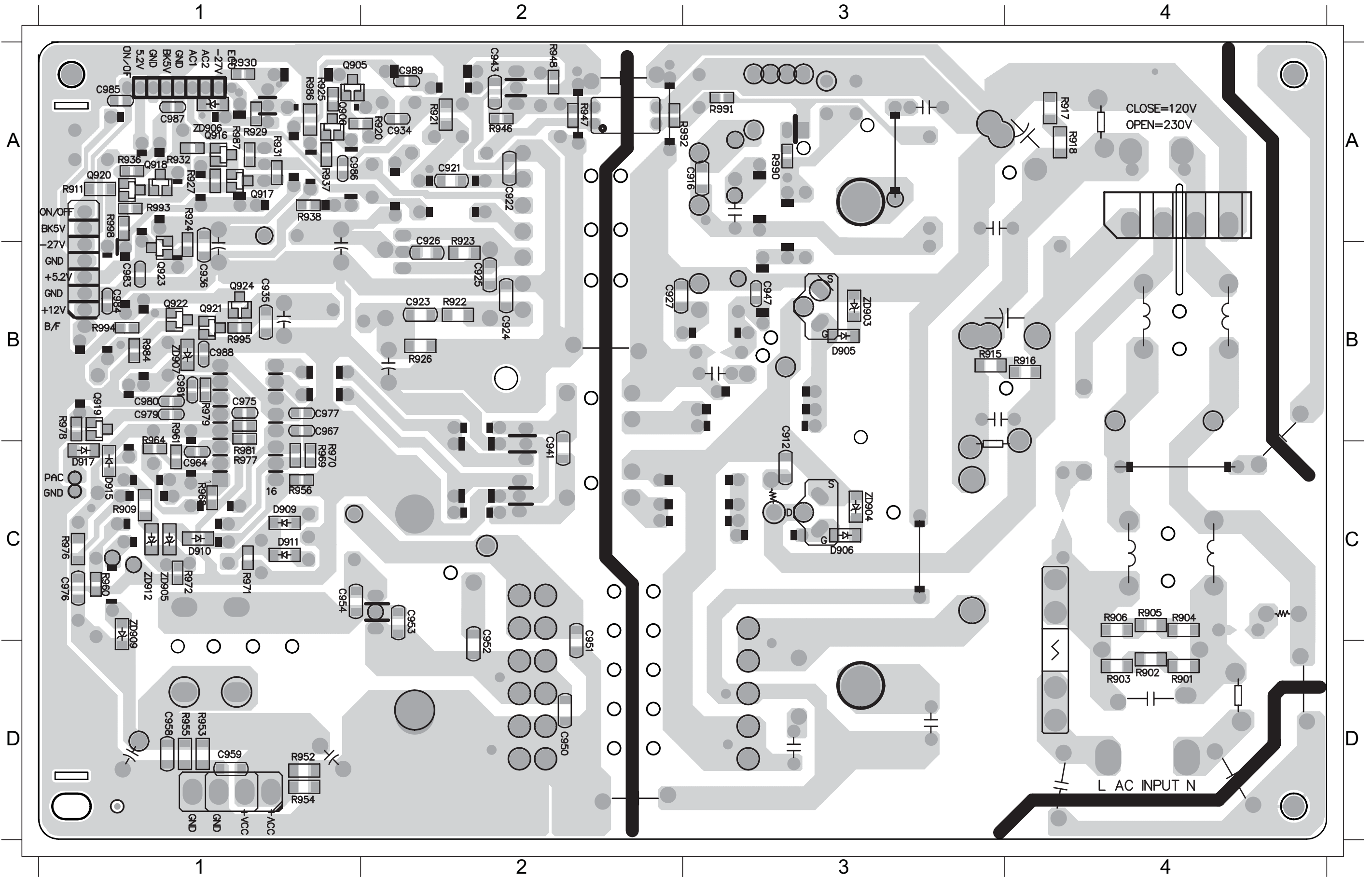

AMP BOARD

TABLE OF CONTENTS

Circuit Diagram.....8-1
 PCB Layout Top View8-2
 PCB Layout Bottom View8-3

8 - 1
INTERNAL IC DIAGRAM - TAS5352ADDV

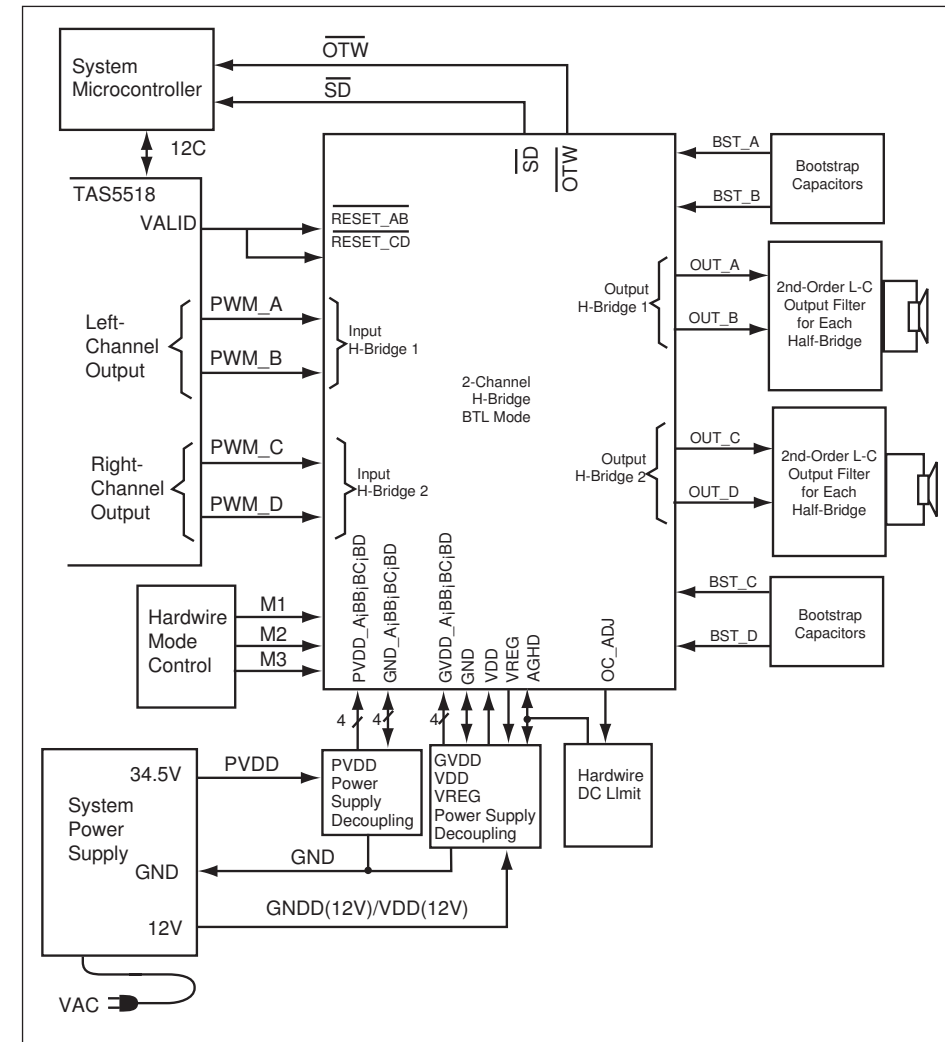

INTERNAL IC DIAGRAM - TAS5508APAG

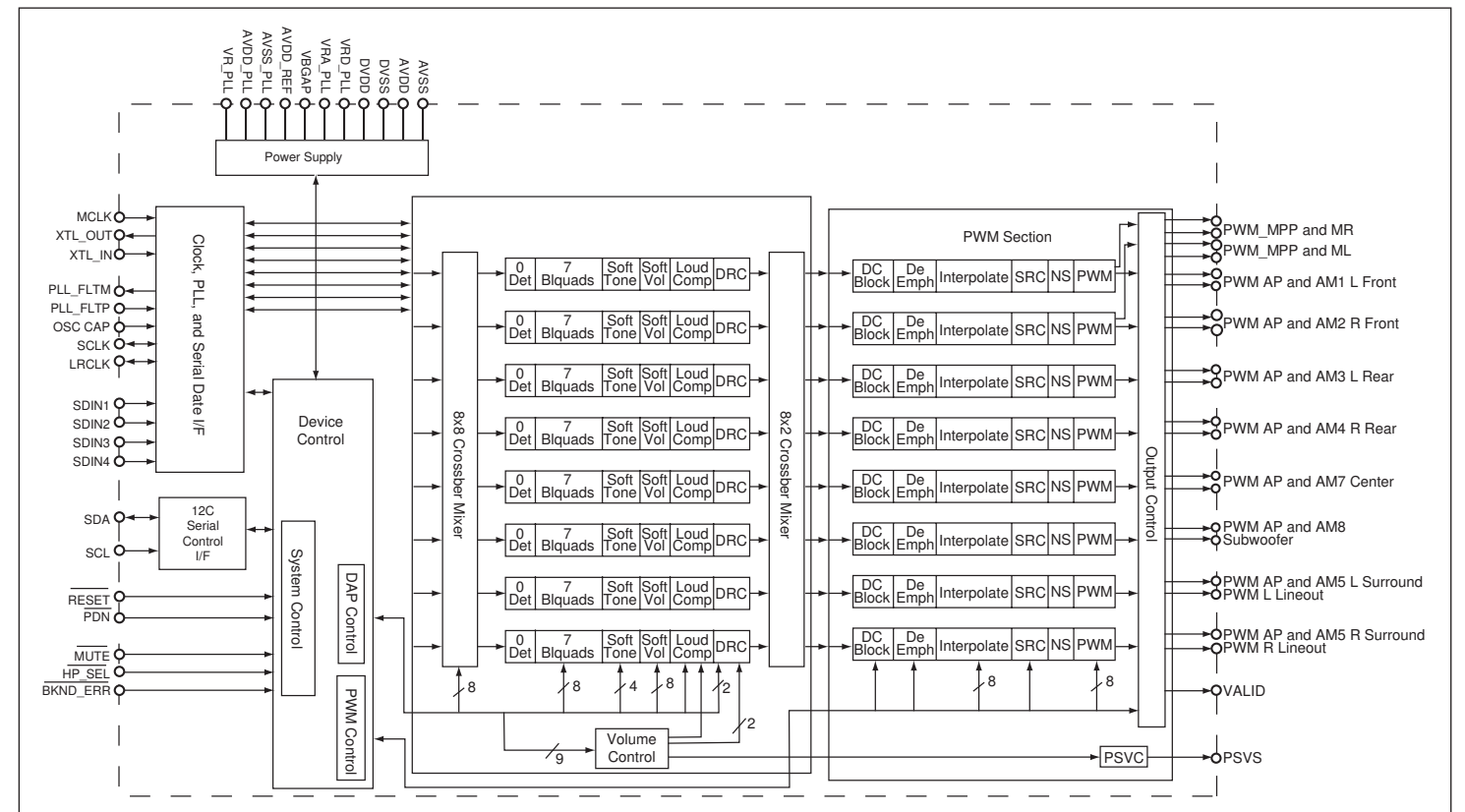

CIRCUIT DIAGRAM

C5001 A1	C5017 C1	C5038 B3	C5053 C2	C5067 D2	C5081 B3	C5095 B2	C5109 B3	C5123 B3	C5138 B2	C5162 D1	C5178 C4	C5192 A4	C5224 D2	FB5003 C1	L5006 A4	L5024 B2	R5003 A1	R5019 B3	R5049 B1	R5064 D4	R5102 C2	R5116 D2	R5131 C1	R5148 C3	R5162 D4	R5177 A3	R5193 A4
C5002 A1	C5018 B3	C5039 B4	C5054 C2	C5068 D4	C5082 B3	C5096 B2	C5110 B3	C5124 B3	C5139 B4	C5163 D1	C5179 D1	C5193 A4	C5210 D2	IC5001 B1	L5007 B1	L5025 B4	R5004 A1	R5029 D3	R5050 B2	R5079 D1	R5103 C2	R5117 D2	R5133 C2	R5149 D3	R5163 D4	R5178 A3	R5194 A4
C5003 A1	C5019 B3	C5041 C1	C5055 C3	C5069 D4	C5083 B4	C5097 B2	C5111 B4	C5125 B4	C5149 C1	C5164 D1	C5180 D1	C5194 A4	CN5002 C4	IC5002 B2	L5008 B1	L5026 B4	R5005 A2	R5032 C2	R5051 B2	R5082 D2	R5104 C2	R5118 D2	R5134 C4	R5150 D3	R5164 C4	R5179 A4	R5213 D3
C5004 A1	C5027 D3	C5042 C1	C5056 C3	C5070 B1	C5084 B4	C5098 B2	C5112 B4	C5127 B1	C5150 C1	C5165 D1	C5181 A4	C5195 B4	CN5003 D1	IC5003 B3	L5009 B2	L5027 B2	R5006 A2	R5035 D3	R5052 B2	R5083 D2	R5105 C3	R5120 C1	R5135 C4	R5151 D3	R5165 C1	R5180 A4	RB5001 C1
C5005 A2	C5028 C3	C5043 C1	C5057 C3	C5071 B1	C5085 B4	C5099 B2	C5113 B4	C5128 A3	C5151 C2	C5166 C3	C5182 A3	C5196 B4	D5005 C4	IC5004 B4	L5011 B2	L5028 B2	R5007 A2	R5036 C2	R5053 B3	R5084 D2	R5106 C3	R5121 C2	R5136 D1	R5152 D4	R5167 A3	R5181 A4	RB5002 D3
C5006 A2	C5029 D3	C5044 C1	C5058 C3	C5072 B1	C5086 B1	C5100 B2	C5114 B1	C5129 B2	C5152 D2	C5167 D1	C5183 A3	C5197 B4	D5006 C3	IC5006 C2	L5012 B3	L5029 B3	R5008 A3	R5037 D3	R5054 B4	R5093 C1	R5107 C3	R5122 C3	R5138 D1	R5153 D3	R5168 A4	R5182 A4	RB5004 C1
C5007 A2	C5030 C3	C5045 C1	C5059 C4	C5073 B1	C5087 B1	C5101 B2	C5115 B1	C5130 A4	C5153 D2	C5168 D1	C5184 A3	C5198 B4	D5007 D3	IC5007 D4	L5013 B3	L5030 B4	R5009 A3	R5038 C3	R5056 C1	R5094 C2	R5108 C3	R5123 C4	R5139 D1	R5154 D4	R5169 A4	R5183 C3	XL5001 D2
C5008 A3	C5031 C3	C5046 C1	C5060 C4	C5074 B2	C5088 B1	C5102 B3	C5116 B1	C5131 B3	C5154 D2	C5169 D1	C5185 A3	C5210 A3	D5008 C3	IC5008 D2	L5014 B2	Q5006 C4	R5010 A3	R5039 D3	R5057 C1	R5095 C2	R5109 C3	R5124 C1	R5140 D2	R5155 D4	R5170 A4	R5184 C2	
C5009 A3	C5032 B1	C5047 C1	C5061 C4	C5075 B2	C5089 B1	C5103 B3	C5117 B1	C5132 A4	C5155 D2	C5170 D1	C5186 A3	C5211 A3	D5009 D3	JK5001A2	L5015 B1	Q5007 C4	R5011 A3	R5040 C3	R5058 C1	R5096 C3	R5110 D1	R5125 C2	R5141 D2	R5156 D4	R5171 A3	R5185 C1	
C5010 A3	C5033 B1	C5048 C2	C5062 D1	C5076 B2	C5090 B1	C5104 B3	C5118 B2	C5133 B4	C5156 D2	C5171 D2	C5187 A3	C5212 A3	D5010 C3	L5001 A1	L5016 B1	Q5008 C4	R5012 A4	R5042 C4	R5059 C2	R5097 D2	R5111 D2	R5126 C2	R5143 D3	R5157 C4	R5172 A3	R5186 C3	
C5011 A3	C5034 B1	C5049 C2	C5063 D1	C5077 B2	C5091 B1	C5105 B3	C5119 B2	C5134 B1	C5158 D2	C5173 D3	C5188 A3	C5213 A3	D5011 D3	L5002 A1	L5017 B4	Q5009 C4	R5014 B1	R5043 C4	R5060 C2	R5098 C1	R5112 D2	R5127 C3	R5144 C3	R5158 D4	R5173 A3	R5187 C2	
C5012 A4	C5035 B2	C5050 C2	C5064 D2	C5078 B2	C5092 B1	C5106 B3	C5120 B2	C5135 B1	C5159 D2	C5174 D2	C5189 A4	C5214 A3	D5012 D3	L5003 A2	L5019 B3	Q5011 D3	R5015 B2	R5044 C4	R5061 C3	R5099 C1	R5113 D2	R5128 C4	R5145 C3	R5159 D4	R5174 A3	R5190 A4	
C5014 D3	C5036 B2	C5051 C2	C5065 D2	C5079 B3	C5093 B1	C5107 B3	C5121 B3	C5136 B3	C5160 D2	C5175 D3	C5190 A4	C5219 C1	FB5001 C3	L5004 A2	L5020 B3	R5001 A1	R5017 C1	R5047 B1	R5062 C3	R5100 C1	R5114 D2	R5129 C4	R5146 D3	R5160 C4	R5175 A3	R5191 A4	
C5015 B2	C5037 B3	C5052 C2	C5066 D2	C5080 B3	C5094 B2	C5108 B3	C5122 B3	C5137 B3	C5161 D2	C5177 D4	C5191 A4	C5223 D1	FB5002 C1	L5005 A3	L5023 B2	R5002 A1	R5018 B3	R5048 B1	R5063 C4	R5101 C1	R5115 D2	R5130 C1	R5147 D3	R5161 C4	R5176 A3	R5192 A4	

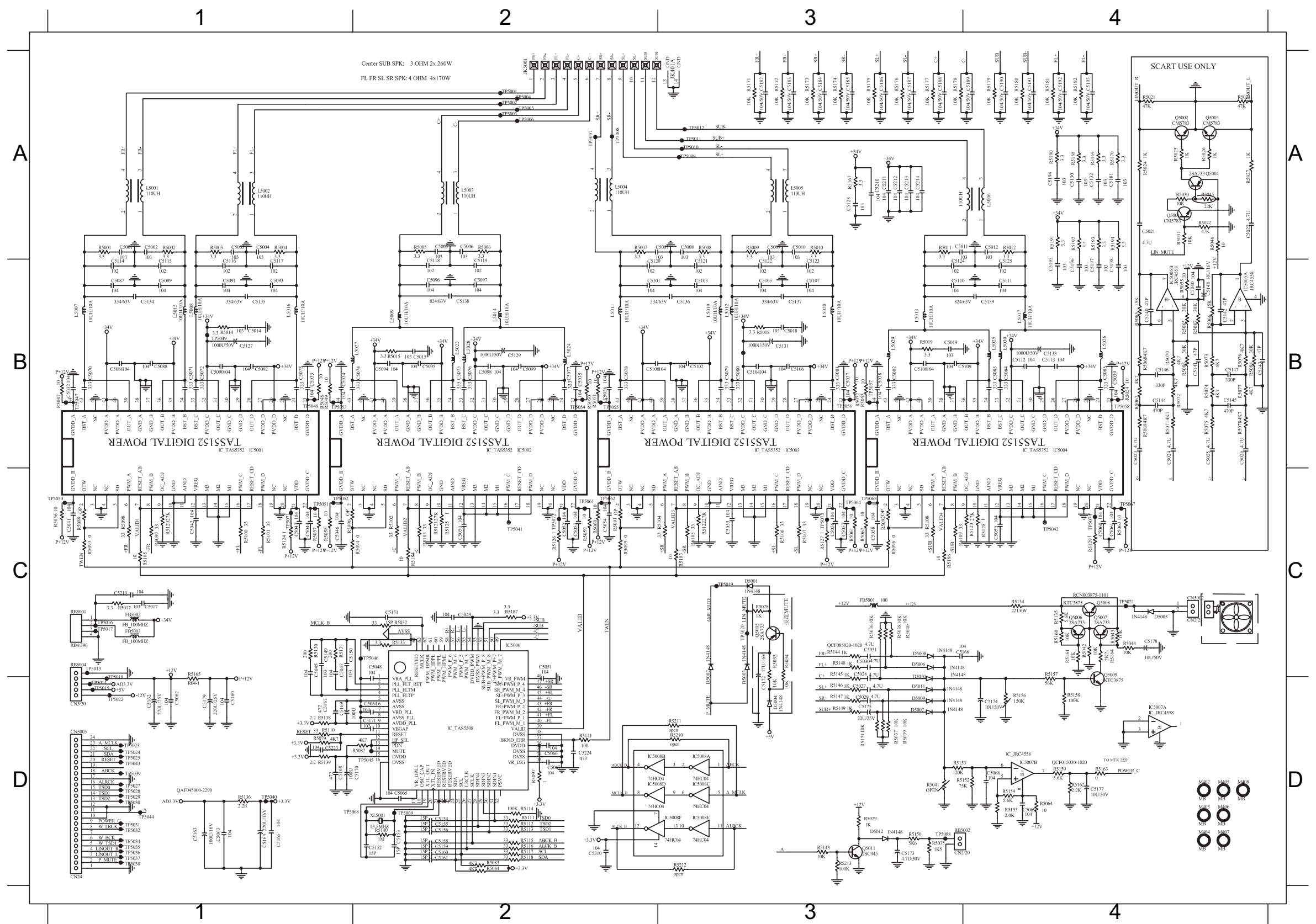

PCB LAYOUT - TOP VIEW

8-3

8-3

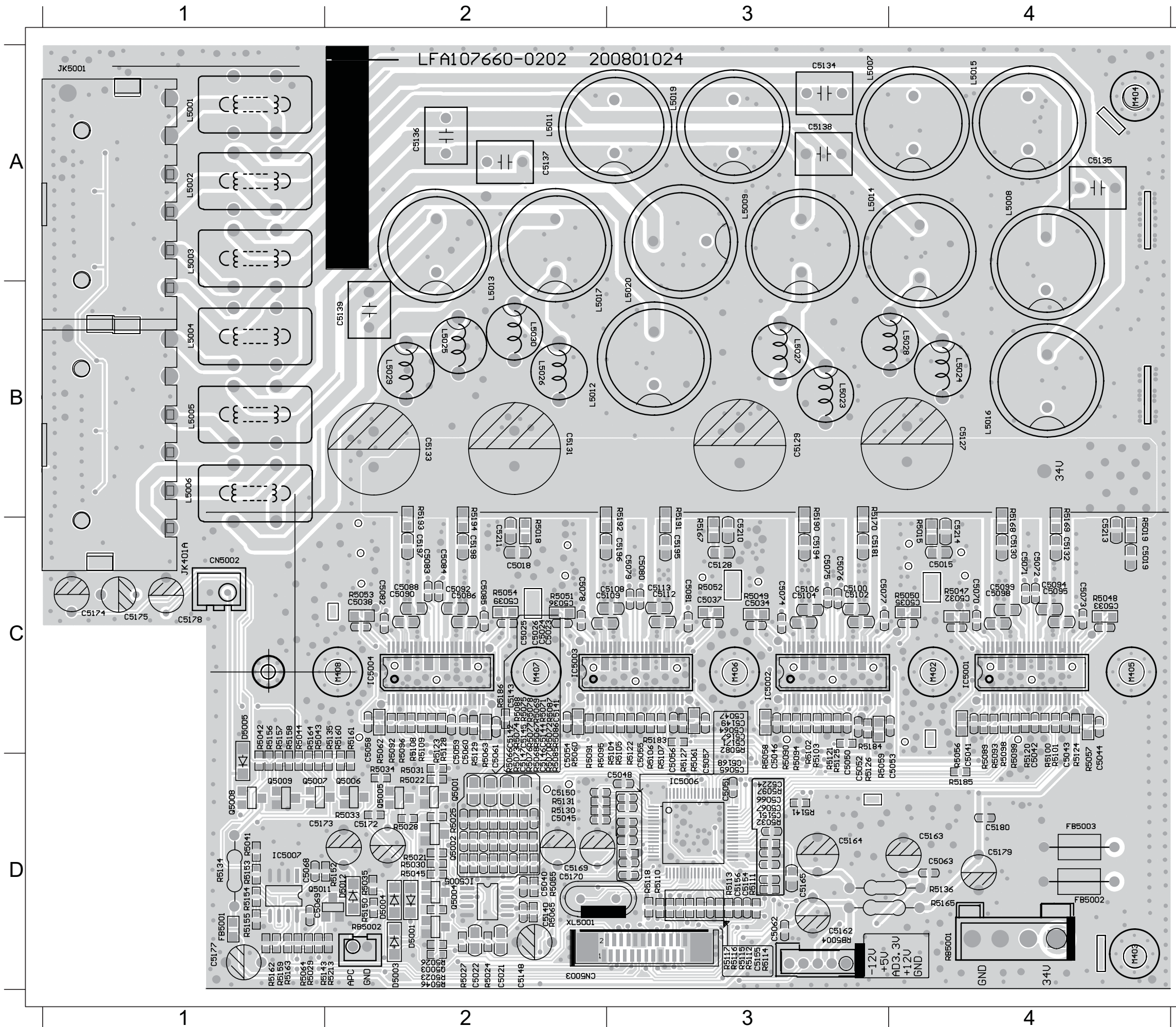

JK5001A1	C5082	C2	R5059	C3	R5143	D1	
L5001	A1	C5083	C2	R5061	C3	R5153	D1
L5002	A1	C5084	C2	R5082	C3	R5154	D1
L5003	A1	C5085	C2	R5094	C3	R5155	D1
C5136	A2	C5086	C2	R5102	C3	R5159	D1
C5137	A2	C5088	C2	R5103	C3	R5162	D1
L5011	A2	C5090	C2	R5104	C3	R5163	D1
L5013	A2	C5092	C2	R5105	C3	C5045	D2
C5134	A3	C5109	C2	R5106	C3	C5150	D2
C5138	A3	C5197	C2	R5107	C3	C5169	D2
L5007	A3	C5198	C2	R5121	C3	C5170	D2
L5009	A3	C5211	C2	R5122	C3	CN5003	D2
L5014	A3	IC5003	C2	R5125	C3	D5012	D2
L5019	A3	IC5004	C2	R5127	C3	Q5006	D2
C5135	A4	R5018	C2	R5167	C3	R5035	D2
L5008	A4	R5051	C2	R5183	C3	R5130	D2
L5015	A4	R5053	C2	R5184	C3	R5131	D2
L5004	B1	R5054	C2	C5015	C4	R5150	D2
L5005	B1	R5060	C2	C5019	C4	R5152	D2
L5006	B1	R5062	C2	C5032	C4	R5213	D2
C5131	B2	R5063	C2	C5033	C4	RB5002	D2
C5133	B2	R5095	C2	C5035	C4	XL5001	D2
C5139	B2	R5096	C2	C5041	C4	C5048	D3
L5012	B2	R5108	C2	C5042	C4	C5051	D3
L5017	B2	R5109	C2	C5043	C4	C5052	D3
L5025	B2	R5123	C2	C5044	C4	C5056	D3
L5026	B2	R5128	C2	C5053	C4	C5062	D3
L5029	B2	R5129	C2	C5070	C4	C5065	D3
L5030	B2	R5135	C2	C5071	C4	C5066	D3
R5193	B2	R5160	C2	C5072	C4	C5067	D3
R5194	B2	R5161	C2	C5073	C4	C5151	D3
C5129	B3	R5186	C2	C5094	C4	C5154	D3
L5020	B3	C5034	C3	C5095	C4	C5155	D3
L5023	B3	C5037	C3	C5098	C4	C5156	D3
L5027	B3	C5046	C3	C5099	C4	C5162	D3
R5170	B3	C5047	C3	C5130	C4	C5164	D3
R5190	B3	C5050	C3	C5132	C4	C5165	D3
R5191	B3	C5055	C3	C5213	C4	C5168	D3
R5192	B3	C5057	C3	C5214	C4	C5224	D3
C5127	B4	C5058	C3	IC5001	C4	IC5006	D3
L5016	B4	C5064	C3	R5015	C4	R5032	D3
L5024	B4	C5074	C3	R5019	C4	R5097	D3
L5028	B4	C5076	C3	R5047	C4	R5110	D3
R5168	B4	C5077	C3	R5048	C4	R5111	D3
R5169	B4	C5079	C3	R5050	C4	R5112	D3
C5174	C1	C5080	C3	R5056	C4	R5113	D3
C5175	C1	C5081	C3	R5057	C4	R5114	D3
C5178	C1	C5100	C3	R5093	C4	R5115	D3
CN5002	C1	C5102	C3	R5098	C4	R5116	D3
D5005	C1	C5104	C3	R5099	C4	R5117	D3
R5042	C1	C5106	C3	R5100	C4	R5118	D3
R5043	C1	C5108	C3	R5101	C4	R5126	D3
R5044	C1	C5112	C3	R5120	C4	R5141	D3
R5156	C1	C5113	C3	R5124	C4	RB5004	D3
R5157	C1	C5128	C3	C5068	D1	C5063	D4
R5158	C1	C5149	C3	C5069	D1	C5163	D4
R5164	C1	C5167	C3	C5173	D1	C5179	D4
C5018	C2	C5171	C3	C5177	D1	C5180	D4
C5036	C2	C5181	C3	FB5001	D1	FB5002	D4
C5038	C2	C5194	C3	IC5007	D1	FB5003	D4
C5039	C2	C5195	C3	Q5007	D1	R5136	D4
C5054	C2	C5196	C3	Q5008	D1	R5165	D4
C5059	C2	C5210	C3	Q5009	D1	R5185	D4
C5060	C2	IC5002	C3	Q5011	D1	RB5001	D4
C5061	C2	R5049	C3	R5029	D1		
C5075	C2	R5052	C3	R5064	D1		
C5078	C2	R5058	C3	R5134	D1		

PCB LAYOUT - BOTTOM VIEW

8 - 4

8 - 4

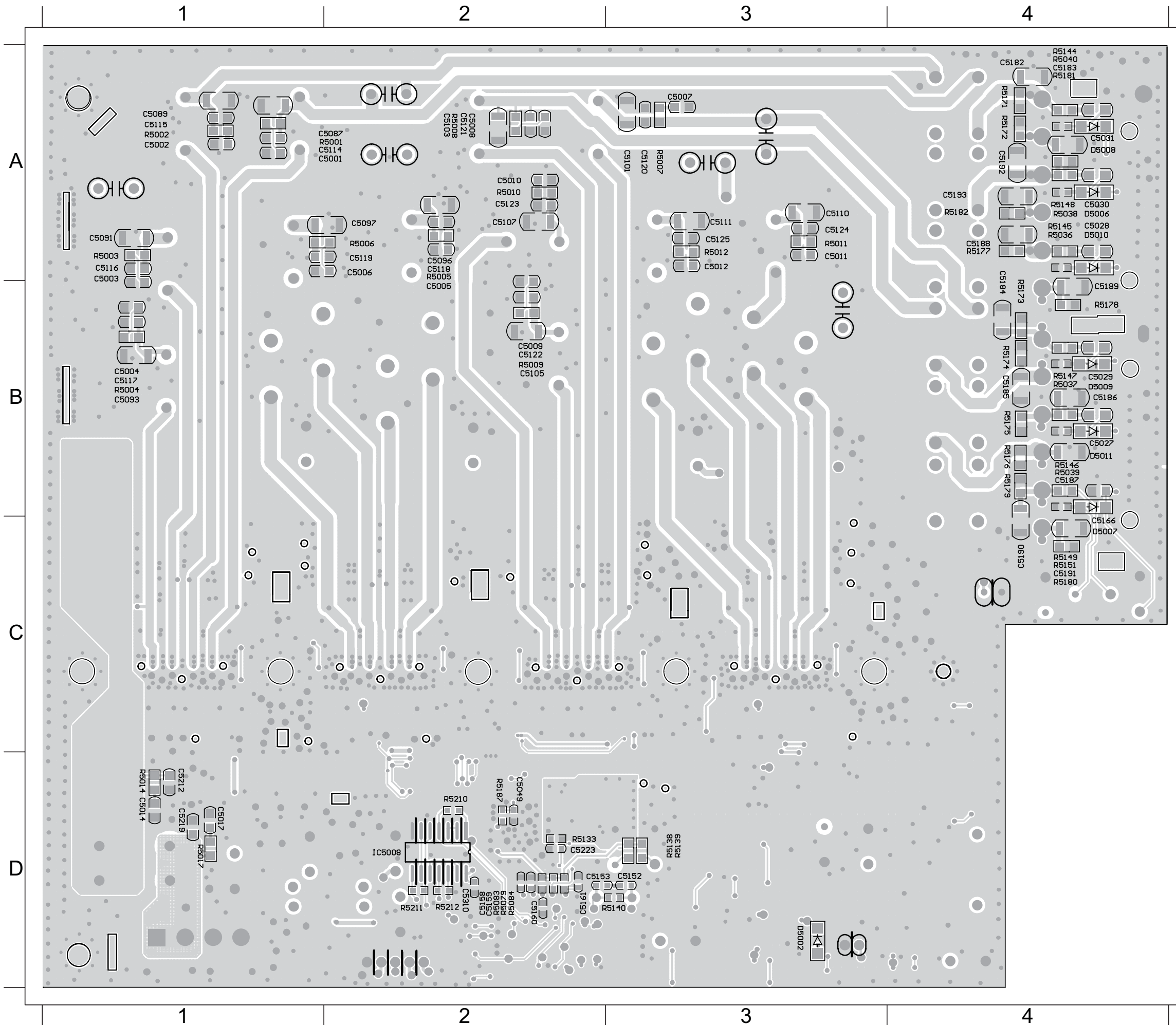

C5001	A1	R5181	A4
C5002	A1	R5182	A4
C5003	A1	C5004	B1
C5087	A1	C5093	B1
C5089	A1	C5117	B1
C5091	A1	R5004	B1
C5114	A1	C5005	B2
C5115	A1	C5009	B2
C5116	A1	C5105	B2
R5001	A1	C5122	B2
R5002	A1	R5009	B2
R5003	A1	C5027	B4
C5006	A2	C5029	B4
C5008	A2	C5185	B4
C5010	A2	C5186	B4
C5096	A2	C5187	B4
C5097	A2	C5189	B4
C5103	A2	D5009	B4
C5107	A2	D5011	B4
C5118	A2	R5037	B4
C5119	A2	R5039	B4
C5121	A2	R5146	B4
C5123	A2	R5147	B4
R5005	A2	R5173	B4
R5006	A2	R5174	B4
R5008	A2	R5175	B4
R5010	A2	R5176	B4
C5007	A3	R5178	B4
C5011	A3	R5179	B4
C5012	A3	C5166	C4
C5101	A3	C5190	C4
C5110	A3	C5191	C4
C5111	A3	D5007	C4
C5120	A3	R5149	C4
C5124	A3	R5151	C4
C5125	A3	R5180	C4
R5007	A3	C5014	D1
R5011	A3	C5017	D1
R5012	A3	C5212	D1
C5028	A4	C5219	D1
C5030	A4	R5014	D1
C5031	A4	R5017	D1
C5182	A4	C5049	D2
C5183	A4	C5153	D2
C5184	A4	C5158	D2
C5188	A4	C5159	D2
C5192	A4	C5160	D2
C5193	A4	C5161	D2
D5006	A4	C5223	D2
D5008	A4	C5310	D2
D5010	A4	IC5008	D2
R5036	A4	R5079	D2
R5038	A4	R5083	D2
R5040	A4	R5084	D2
R5144	A4	R5133	D2
R5145	A4	R5187	D2
R5148	A4	C5152	D3
R5171	A4	R5138	D3
R5172	A4	R5139	D3
R5177	A4	R5140	D3

Mechanical Exploded View

9 - 1

9 - 1

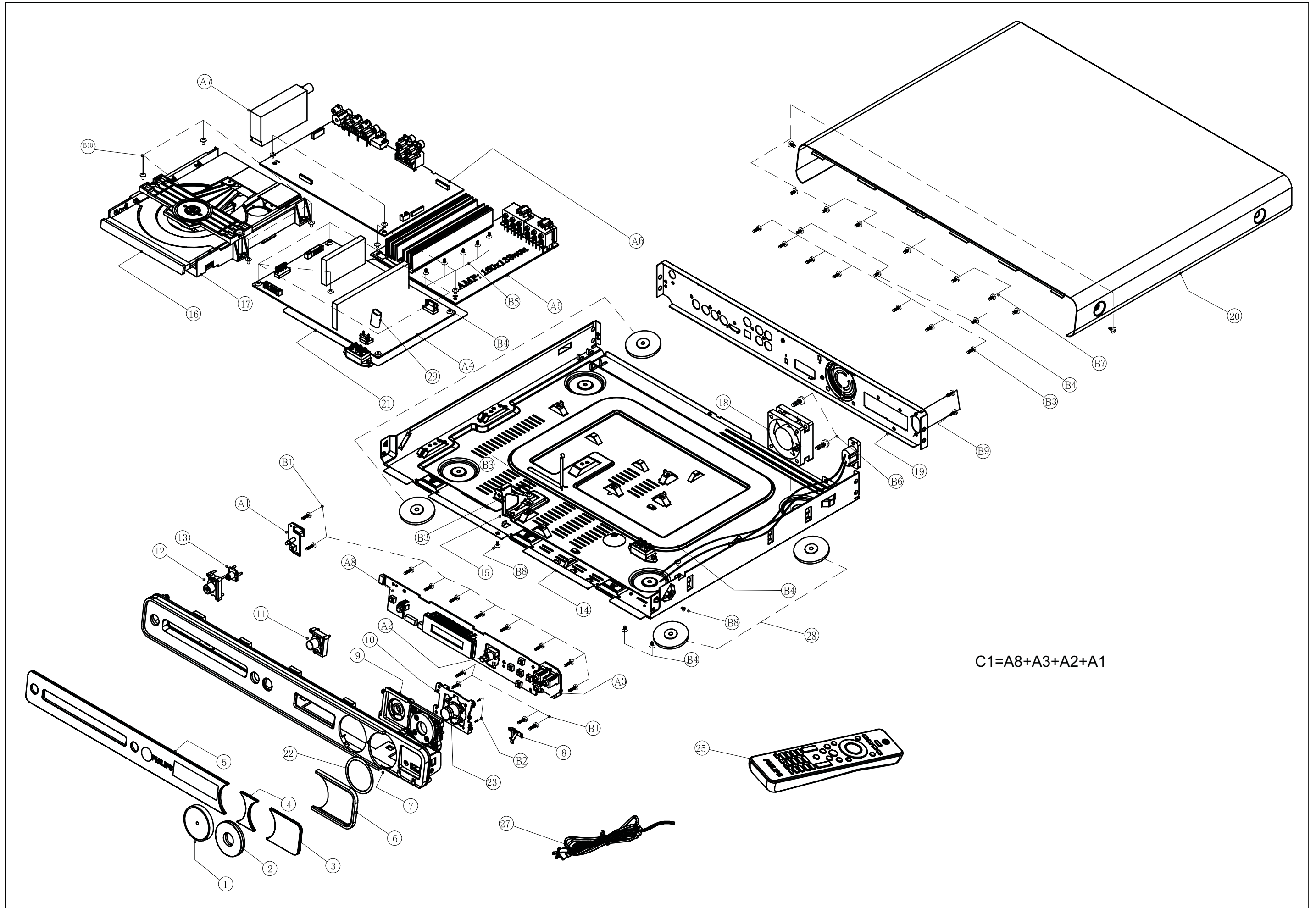

PART LIST

Loc.	Part No.	Description
MAIN UNIT		
1	996510021087	VOLUME KNOB
10	996510021586	SOURCE BUTTON BKT
11	996510021601	OPEN/CLOSS BUTTON
12	996510021561	STANDBY BUTTON
13	996510021064	STANDBY LENS
14	996510021569	BTM CABINET
16	996510022914	DVD DOOR
17	996510021248	DVD LOADER
18	996510021564	FAN 12V 0.55A
19	996510022916	BACK PANEL
2	996510021567	FUNCTION BUTTON
20	996510021619	TOP CABINET
23	996510021568	SOURCE BUTTON
25	996510021186	REMOTE CONTROL
27	996510001638	POWER CORD
28	996510021942	RUBBER FOOT D14xH4.2
3	996510021595	DOOR LENS
4	996510021566	MINI LENS
5	996510021592	DISPLAY LENS
6	996510021588	FLAP DOOR
7	996510021597	FRONT PANEL
9	996510021602	FUNCTION_BTN_BKT
A7	996510017572	TUNERPACK KST-MT001FS0-6BKWANG
FC	996510001599	RUBBER FOOT -CENTER SPK
FM	996510008251	FM ANT
V1	996510007429	GP FCCBLE 10P100mmUL20798 P=1
V2	996510021598	FFC CABLE 24P 60mm
VIDEO	996500013058	RCA CABLE 2P 1.2M
Screw	996510017273	SCREW

SPEAKER

FS	996510013306	RUBBER FOOT -SUB
MS	996510012224	RUBBER FOOT - REAR
SPKC	996510022915	SPEAKER BOX Center
SPKFL	996510022921	SPEAKER BOX F-L
SPKFR	996510022917	SPEAKER BOX F-R
SPKSL	996510022913	SPEAKER BOX S-L
SPKSR	996510022918	SPEAKER BOX S-R
SPKSUB	996510021582	SPEAKER BOX-SUB

SCREW

B8	--	M3x0.5Px6mm
B2	--	T2x0.63PxL5mm NICKEL
B1	--	T2.6x0.91PxL8mm NICKEL
B3	--	T3.0x1.06PxL8mm NICKEL
B5	--	T3.0x1.06PxL10mm NICKEL
B6	--	PAN HEAD STEEL L10xP2.12xT5.0mm
B10	--	M3.0x0.5PxL8mm NICKEL
B9	--	T3.5xL10.0xP1.41mm NICKEL PLATE
B4	--	M3.0x0.5PxL6mm NICKEL
B7	--	M3x6x0.5P

MAIN+Y.U.V PCB

CN201	996500015859	CONNECTOR 4PIN P2.0MM
CN202	996510012494	CONNECTOR 5 PIN RED
CN204	996500017367	CONNECTOR 8P
CN205	996510012495	CONNECTOR 4P
CN206	996500015900	CONNECTOR 3 PIN P=2.0MM
CN208	996500015897	CONNECTOR 3 PIN RED P=2.0MM
CN301	996510012497	FPC/FFC CONN. 10P
CN303	996500015861	CONNECTOR B4B-XH-A 4 PIN
CN401	996500015895	CONNECTOR 5 PIN P=2.0MM
CN802	996500015901	CONNECTOR 6 PIN P=2.0MM
D201	996510010358	DIODE 1N4007
D204	996510010358	DIODE 1N4007
IC201	996510012499	IC 28P
IC202	996510021937	IC 48P KH29LV320DBTC-70G
IC203	994000005209	IC 3P AZ809NSTR-E1 SOT23
IC204	996510004289	IC 8P TU24C16CS2 SOIC TURBO
IC205	996500027091	IC 3PIN AP1117E33LA SOT223 3.
IC206	996510016601	IC 54P HY57V641620F(L/S)TP-6
IC207	996510012500	IC 20 PIN SN74HC244PWR TSSOPT1
IC208	996510021936	IC 48P STM32F101C6A
IC209	996510021082	IC 256P MT1389FXE/SN LQFP
IC210	996500027090	IC 3 PIN AP1117E18LA 1.8V SOT2
IC3001	996500029611	IC 8P CO4558A SO8 CERAMATE LF
IC3001	996510020341	IC 8P D4558 SOP SILICORE
IC304	996510012503	IC 16P CD4051BM SOIC TI ANALOG
IC306	996510021056	IC 20P WM8781GEDS SSOP WOLFSON
IC501	996510012505	IC 48P CS48540-CQZ LQFP CIRRUS
IC801	996510012506	IC 28P AM5888S L/F HSOP AMTEK
JK206A	996510021571	FIBER OPTICAL RECEIVER
JK206B	996510021591	RCA JACK 1P ORANGE W/GND
JK302	996510004283	RCA JACK 4P AUDIO
JK601	996510012507	HDMI JACK 19P PDVBT8-19 FLBS4N
JK701	996510012481	RCA JACK 1P YELLOW W/GND
JK702	996500012609	RCA JACK R/G/B
JK703	996510021563	RCA JACK + TOSL. JACK ASSY
Q201	994000000915	XISTR NPN 2SC1623
Q204	996510012508	XISTR PNP TIP42C
Q205	996510000578	XISTR NPN KTC3875-Y
Q602	996500041281	FET 2N7002 60V/115MA
Q801	996510004117	FET 2SK3018 30V/0.1A SC-70
Q803	996500026927	XISTR PNP 2SB1132RT100 ROHM HF
Q901	996510000615	XISTR NPN 2SC945P
Q903	996500026946	XISTR PNP 2SB772P/Q NEC PB<10
XL501	996510000566	CRYST 24.576MHZ +/-20PPM
ZD901	994000005204	DIODE ZENR 12.6-13.1V 0.5W
ZD904	996500028741	DIODE ZENR 9.1-9.5V 0.5W PB<10

POWER PCB

BD901	996510011372	BRIDGE KBU808 8A 800V
C902	996500018042	COND DISC 0.01UF 1KV 20%
C906	996500027115	CAP.SAFETY Y1 102PF 250V 20% Y5
C907	996510012548	GOND SAFETY 0.47uF 275V 10% X2
C908	996500027123	CAP.E 330UF 200V 20% 105°C D18
C910	996500027124	COND METAL 1.5UF 250V DC /-10
C913	996500020264	COND DISC 470PF 1KV 10%
C915	996500027125	COND DISC 0.0022UF 1KV 20% Y5P
C917	994000005343	COND SAFETY 0.22UF 275V 20%
C965	994000005344	CAP.SAFETY Y1 560PF 400V 10%
CN901	996510018268	CONNECTOR 4P P=3.96mm180' NICK
CN902	996500017458	CONNECTOR 3P CL3962WVO
CN903	996510021055	CONNECTOR B7B-XH-A 7 PIN
CN904	996500017358	CONNECTOR 7P
CN905	996510016729	CONNEC 4P P=3.96mm 180' NICKEL
CN906	996500015898	CONNECTOR 2 PIN PITCH=2.0MM
D902	996500026949	DIODE SW 1N4148 PB<1000PPM
D903	996500026949	DIODE SW 1N4148 PB<1000PPM
D904	994000005346	RECTIFIER UF1602CT TO-220AB 3P
D907	996500026949	DIODE SW 1N4148 PB<1000PPM

D908	996500026949	DIODE SW 1N4148 PB<1000PPM
D918	996510012516	DIODEHER105 DO-411A400V50nSFMS
D920	994000000938	DIODE PR1507 1.5A 1000V
D922	996500041297	DIODE SB560 DO-201AD CTC 5A 60
D923	996500038438	DIODE HER503 5A 200V
F901	994000001053	FUSE 6.3A 250V
GT902	996510021084	SURGE PROTECTOR DSP-501N-A21F
IC902	996510021079	IC 8P(P3=N.C) TNY180PN DIP-8C
IC903	994000000946	OPTICAL SENSOR 4P
IC904	996500029312	IC 3 PIN TL431 TO-92 CHANG JI
IC905	996510008293	IC 16P AZ7500BP-E1
L901	996510013776	LINE FILTER ET-24
L902	996510013747	LINE FILTER ET-28
L903	996500016694	6UH 13.5TS 2UEW
L907	996500027102	TOROID COIL S1=1TS D0.65MMX2 P
L908	994000005341	COMMON COIL 65UH +/-10% 2XD1.2
NTC901	996510008294	NTC THERMISTOR
Q905	994000000915	XISTR NPN 2SC1623
Q906	994000000921	XISTR PNP 2SA812 HFE:200-400
Q910	996500026946	XISTR PNP 2SB772P/Q NEC PB<10
Q912	996510012517	MOSFETFQP13N50C TO220FAIRCHILD
Q923	996510018395	FET AO3401 SOT23 -30V/-4.2A
Q925	996510010356	XISTR PNP 2SB647 TO-92MOD
R908	996510012519	RES. 120 OHM 3W 5% MOF
R943	996510012519	RES. 120 OHM 3W 5% MOF
T901	996510021236	TRASFO. EEL-25 7+7P 40W
T902	994000001057	SW. MODEL TRANSFORMER
T903	996510021575	SW. TRASFO FERRITE
TVR901	996510011373	METAL OXIDE VARISTOR 50A560V
TVR902	996510021072	SURGEORBER :VCR-10D241KSP
ZD902	996500027139	DIODE ZENR 23.6-24.7V 0.5W PB<
ZD908	996500029604	DIODE ZENR 19.5-20.4V 0.5W
ZD910	996500026940	DIODE ZENR 11.9-12.4V 0.5W

AMP PCB

CN5002	996500015862	CONNECTOR B2B-XH-A 2 PIN
IC5001	996510021081	IC 44P TAS5352ADDV HTSSOP TI
IC5006	996510021092	IC 64P TAS5508APAG TQFP TI
IC5007	996510020341	IC 8P D4558 SOP SILICORE
IC5008	996500023948	IC 14PIN 74HCU04D PHILIPS TSOP
JK5001	996510013837	GPSPK JAC12P RD-WT-GRN-GRY-BLU
L5007	996510021061	INDUCTOR 10uH 20% 10A
L5023	996510021604	AIR COIL 30NH I=10A
Q5006	994000000921	XISTR PNP 2SA812 HFE:200-400
Q5008	996510000578	XISTR NPN KTC3875-Y
XL5001	996510021233	X'TAL 13.5MHz 15ppm 20pF

VFD+JACK+VOL+STDBY PCB

IC11	996500029614	IC 52 PIN PT6311(PTC)
JK11	996510004129	KARAOKE JACK D3.6MM 7P
LD11	996510020167	LED 3 DIA ULTRA RED TINT CLEAR
Q11	994000000915	XISTR NPN 2SC1623
Q12	994000000921	XISTR PNP 2SA812 HFE:200-400
SN11	996510021562	IRT RECEIVER IRM-3638TF4
USB11	996510013742	USB JACK 4P

REVISION LIST

Version 1.0
*Initial release